

Laboratory Manual

Physics 2DL

Modern Physics

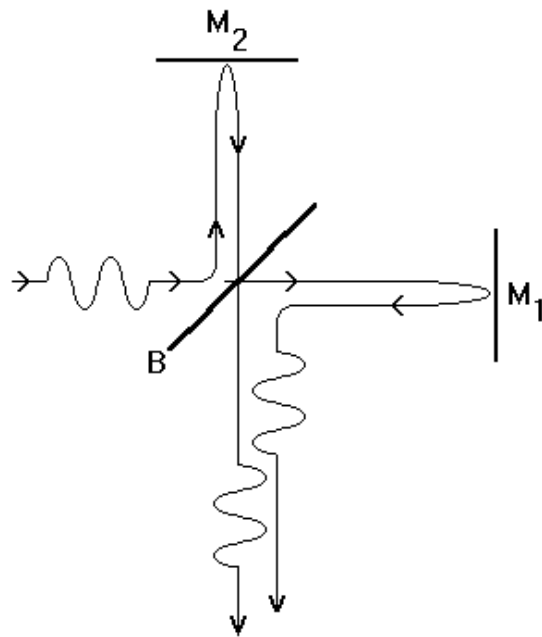

Department of Physics

University of California, San Diego

Professor Brian Keating
Spring 2010

Physical Constants

$$c = 2.9979 \times 10^8 \text{ m/s} \approx 1 \text{ ft/ns}$$

$$c_0 = 343 \text{ m/s} \approx 1 \text{ ft/ms}$$

$$\epsilon_0 = 8.85 \times 10^{-12} \text{ C}^2/\text{N}\cdot\text{m}^2$$

$$\mu_0 = 4\pi \times 10^{-7} \text{ T}\cdot\text{m/A}$$

$$h = 6.626 \times 10^{-34} \text{ J}\cdot\text{s} = 4.136 \times 10^{-15} \text{ eV}\cdot\text{s}$$

$$\lambda = 1240 \text{ nm} \left(\frac{\text{eV}}{\text{eV}} \right)^{-1}$$

$$\lambda_{\text{BB}}^{\text{max}} = 250 \text{ nm} \left(\frac{\text{K}}{\text{eV}} \right)^{-1} = 2.9 \text{ nm K}^{-1}$$

$$e = 1.602 \times 10^{-19} \text{ Coul}$$

$$1 \text{ eV} = 1.602 \times 10^{-19} \text{ Joule} = 11,600 \text{ K kg}$$

$$\frac{1}{40} \text{ eV} \approx 300 \text{ K}$$

$$N_A = 6.022 \times 10^{23}$$

$$m_p = 1.673 \times 10^{-27} \text{ kg} = 938 \text{ MeV}/c^2$$

$$m_e = 9.109 \times 10^{-31} \text{ kg} = 511 \text{ keV}/c^2$$

$$= m_p/1836$$

$$\lambda_e = 1.227 \text{ nm} \left(\frac{\text{eV}}{\text{eV}} \right)^{-1/2}$$

$$a_0 = \frac{h^2 \epsilon_0}{\pi m e^2} = 0.0529 \text{ nm}$$

$$= 0.529 \text{ \AA}$$

$$f = c/\lambda$$

$$c^2 = 1/\mu_0 \epsilon_0$$

$$E = hf$$

$$V = \frac{e}{4\pi \epsilon_0 r} = 27.2 \text{ Volts} \left(\frac{a_0}{r} \right)$$

$$\Delta E = q \Delta V$$

$$E = mc^2$$

$$\lambda_m = \frac{h}{m v}$$

$$= \frac{h}{\sqrt{2m} \sqrt{\frac{1}{2} m v^2}}$$

$$\text{from } \frac{m v_0^2}{r} = \frac{e^2}{4\pi \epsilon_0 r^2}$$

$$\text{and } \lambda_e = \frac{h}{m v_0} = \frac{2\pi r}{n}$$

$$\text{or } L_0 = m v_0 r = n \frac{h}{2\pi}$$

Bulk:

$$1 \text{ A}\cdot\text{h} = 3600 \text{ Coul} = 2.3 \times 10^{22} e^-$$

$$= \frac{N_A}{27} e^-$$

$$1 \text{ A}\cdot\text{h}\cdot\text{Volt} = 3600 \text{ Joules} = \frac{N_A}{27} \text{ eV}$$

EXPERIMENT #1

Optical Spectra and the Diffraction Grating

Goals

Physics

- Learn to use an optical grating to find the dominant spectral lines from a gas discharge tube.
- Try to identify an unknown gas from the observed spectrum.

Technique

- Try to reduce angle measurements to only one variable by picking (and finding) the "optimum" grating angle.

Error Analysis

- Use the arbitrary function relation (Taylor Eqn. 3.23) to relate angle measurement uncertainties to wavelength uncertainties.
- Compare your measurements of known gases to tabulated spectra, for calibration of your technique.

Question (Work out the following before coming to 2D lab)

- Show that the grating relation, $d(\sin \alpha + \sin \theta) = n\lambda$, implies a minimum angle for $\phi (= \theta + \alpha)$ when $\theta = \alpha$. Can you also show that ϕ is independent of small changes in α (the grating angle) when $\theta = \alpha$?

Important Constants

Distance between diffraction grating $d = 1''/25,000 = 1.016 \mu\text{m}$

References

- Serway, Moses, Moyer §3.3, 3.4
- Tipler & Llewellyn §4.1, 4.3

Other references:

- Giancoli, Physics for Scientists and Engineers, 2nd Edition, pages 815-817
- Halliday and Resnick and Walker; Fundamentals of Physics, 1st Edition, page 942-945

BACKGROUND

Identifying substances by their optical spectra is what we will do in this experiment. The quest to understand the composition of materials is a problem that dates back to antiquity. In modern times the measurement of atomic spectra permits us to determine compositions with relative ease, not only in the laboratory, but also across the entire visible universe. Each of the hundred or so elemental substances identifies itself uniquely by the light it emits when it is in a very hot environment. For example, in astronomy hot environments are common and objects such as stars and quasars are observed directly or when their light passes through clouds of gas or dust, as in the following figure. Both the composition of the gas/dust and star/quasar can be determined, as well as the recessional velocity of the object relative to the observer – a fact which allowed astronomer Edwin Hubble to discover the expansion of the universe in 1929.

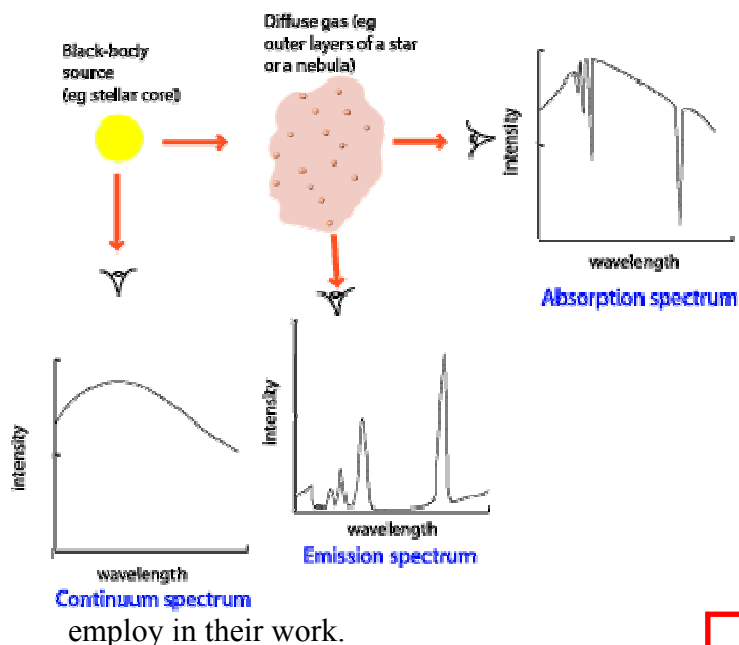
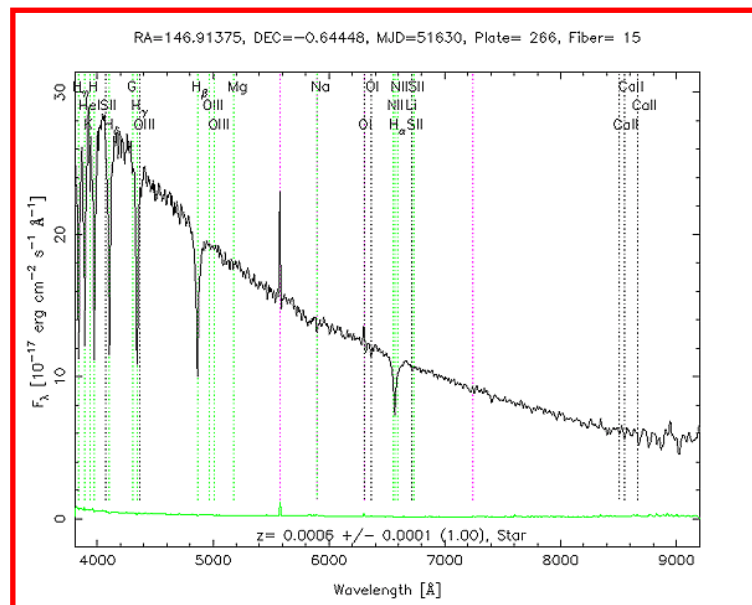

Figure 1 Spectra in an astronomical context. Left figure: Credit: Adapted from a diagram by James B. Kaler, in "Stars and their Spectra," Cambridge University Press, 1989. Right: spectrum from the Sloan Digital Sky Survey spectral database; a typical example of the spectrum of a star.

This particular problem is the whole object of analytical chemistry, and in later courses you will become aware of many elegant methods which chemists are able to

The chemist must, of course, have on hand an adequate amount of the material he/she wishes to investigate, although "adequate" can mean an impressively small quantity in some instances. If an actual sample of the unknown substance cannot be brought into the laboratory, then chemistry fails us, and except for one very fortunate circumstance, we might be out of luck in discovering the composition of the sun and stars, for example.

Atomic Spectra



You are aware by now that atoms consist of heavy, positively-charged nuclei, surrounded by relatively large and tenuous electron "clouds." The overall size of the atom is so small, however, that the behavior of this system of electrons, protons, and neutrons can only be described by Quantum Mechanics. Many of the results of quantum mechanics seem to violate our "common sense" notions of how things should behave; for example, the total energy possessed by any one of the electrons orbiting the nucleus can have certain discrete values and no others. We are familiar with the fact that the energy of a large orbiting body, e.g., a satellite of the earth, can be changed continuously by applying thrust from a rocket. In an atomic system, however, nature simply does not allow this. If any increase or decrease in an electron's energy is to occur, it must take place in instantaneous jumps between energy levels which are characteristic of the particular kind of atom.

These transitions between energy levels may be induced in a number of ways, among them collisions between atoms, and irradiation of an atom with electromagnetic energy. In the case of a downward transition of an electron's energy, the change may occur spontaneously, without external stimuli being involved.

In all of these changes, however, one law from classical (or large-scale) mechanics is still rigorously obeyed: energy must be conserved. When a downward transition of electron energy from energy level W_1 to another energy W_2 occurs, the energy difference $W_1 - W_2$ must show up somewhere else. This "somewhere else" is almost always the radiation of a burst of electromagnetic waves.

What is the nature of this burst of waves? Classical theory is of no help to us here, and the discovery of the actual relationship between the transition energy and the wavelength of the radiation by Max Planck, Albert Einstein, and R. A. Millikan near the turn of the century was the "breakthrough" that led to the development of quantum theory.

Quantum theory relates the total energy, W_{rad} , of the burst to its frequency ν , or wavelength λ , by the equation

$$W_{rad} (= W_1 - W_2) = h\nu = \frac{hc}{\lambda} .$$

Here, c is the velocity of light, and h is a proportionality constant called Planck's constant.

Now, let us assemble several important facts:

1. Each species of atom (i.e. element) is characterized by a certain array of permitted energy levels W_1, W_2, \dots, W_n ; and these levels differ from the levels of every other species.
2. Since atoms are identified by their permitted energy levels, it follows that the various differences between levels in an atom are also a set unique to that atom, and hence, the combination of possible radiation wavelengths one can

obtain from one kind of atom is absolutely unique to it. Spectra are thus sometimes referred to as “fingerprints” of the atom.

3. If a very great number of atoms are in an environment (usually very hot) which permits very large numbers of transitions back and forth between energy levels, there will be a steady flow of radiation from that region. By carefully measuring all the wavelengths present, one may completely identify the various species present there, even though the observer may be astronomical distances away from the source. It is by this means alone that we know the composition of the outer layers of the stars.
4. The radiation emitted by atoms covers a very large range of wavelengths. At the short wavelength end of the scale are x-rays, which are invisible and have the ability to penetrate matter quite easily. In contrast to this, atoms can also generate radiation which has sufficiently long wavelength to be classed as radio microwave energy. This range covers more than seven orders of magnitude, from wavelengths of less than one angstrom unit ($1 \overset{\circ}{\text{A}} = 10^{-8} \text{ cm}$) up to the order of $10^7 \overset{\circ}{\text{A}}$, i.e., 1 mm. In the middle of this range is a band of wavelengths between about $4000 \overset{\circ}{\text{A}}$ and $7000 \overset{\circ}{\text{A}}$, which constitute visible light. The various atomic emissions in this range then appear to us as different colors.

The study of atomic properties through analysis of emission of visible light is called optical spectroscopy. The principal instrument employed in this work is the spectrograph, or spectrometer. It has the function of dispersing an incoming beam of light from the source into separated beams of different colors, so that the various wavelength constituents of the light fall along different positions on some calibrated scale. This linear array of light components from a source is referred to as its spectrum.

In the present experiment, you will employ an elementary spectrometer, which will enable you to identify some elements through observations of their spectra.

The Diffraction Grating

A convenient mental image to employ in thinking about E.M. (electromagnetic) waves is that of a succession of flat "sheets" of electric field, all moving in the “z” direction perpendicular to their planes, and carrying electric fields of alternating direction.

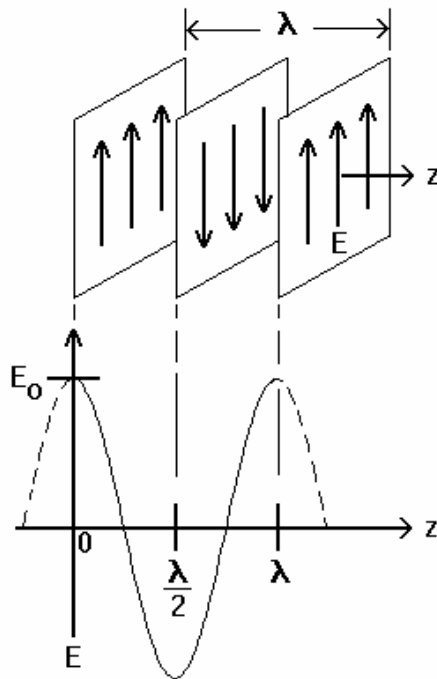

Figure 2

The sheets may be considered as being of infinite width (in and out of the page – the XY plane in the figure above), at least in comparison to their spacing. The separation between two successive sheets of the same sign is the wavelength, λ . One sees, in the graph in Fig. 2, that the actual variation of E along the propagation direction z is sinusoidal, i.e.,

$$E = E_0 \cos \frac{2\pi}{\lambda} z .$$

When a small obstruction is placed in the way of this train of waves, the waves diffract. The obstruction effectively extracts energy from the plane wave incident upon it, and re-radiates the energy in all directions.

Thus, we have two sets of waves--the incident plane waves and the "scattered" or diffracted waves (Fig. 3).

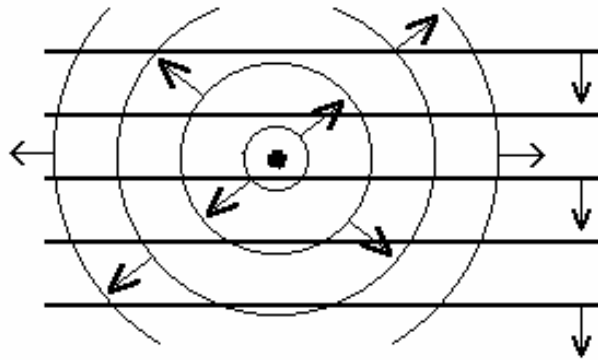

Figure 3

Suppose now that we place several such obstructions in the path of the incident waves; let all of these sites be spaced at a uniform interval, d , along a line. We will first let this line be parallel to the wave fronts, so we get the situation shown in Fig. 4.

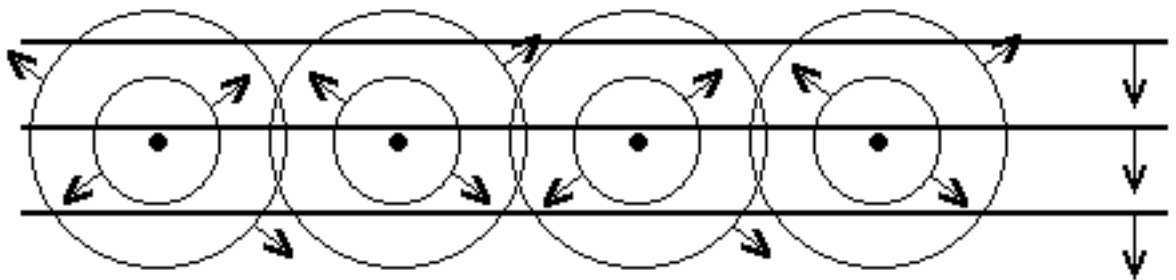

Figure 4

Figure 5 shows the diffracted wavefronts, which are planes of constant phase. We see that the third wave crest from center #1, the second from #2, and the first from #3 are coalescing to produce a new plane wave moving away at angle θ from the initial direction. Each curve in the figure is a positive crest, and so, these are a distance λ apart. One can see from the geometrical construction in the figure that this condition is satisfied if

$$d \sin \theta = \lambda .$$

It is, in fact, satisfied if $d \sin \theta$ is any multiple number of wavelengths, i.e., if

$$d \sin \theta = n \lambda ,$$

where n is any integer.

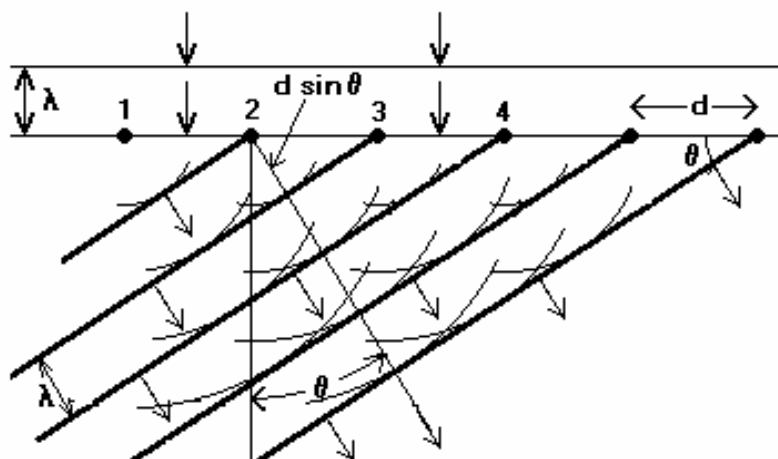

Figure 5

A unique relation between the emerging angle θ of the diffracted wave and wavelength also exists if the incident wave fronts are not parallel to the line of scatterers. The result, which can be easily derived in a manner similar to that used in Fig. 4, is simply

$$d \cdot (\sin \alpha + \sin \theta) = n\lambda \quad , \quad (\text{The grating equation})$$

where now α is the angle between the incident wave fronts and the line of scatterers.

These results immediately suggest a way of dispersing a multi-colored beam of light into its separate colors. If we could build or obtain a scattering array whose members were spaced by a distance d comparable to a wavelength of light, it would be possible to send each component off in a different direction. By measurement of these angles, one might then determine wavelengths, and hence, identify the atomic species producing the light.

Such diffraction gratings can indeed be manufactured; in fact, the majority of all spectrographs produce dispersed spectra through the use of gratings. A typical grating consists of a blank of glass (or a reflecting metal surface) upon which are engraved as many as 25,000 accurately parallel and evenly spaced grooves per inch of surface. This is an expensive process. Fortunately, it is not usually necessary to purchase an original grating in order to produce excellent spectra; "replica" gratings, made by molding of collodion or other plastic material against a good original are at best nearly comparable in performance, and often low enough in cost to be available to almost any experimenter. You will employ in your experiment a small replica grating of 25,000 lines per inch.

To measure the emission wavelengths, the angles of the corresponding diffraction maxima must be measured. One possible method is to pass the light through the grating and project it onto a circular screen as illustrated in Fig. 6.

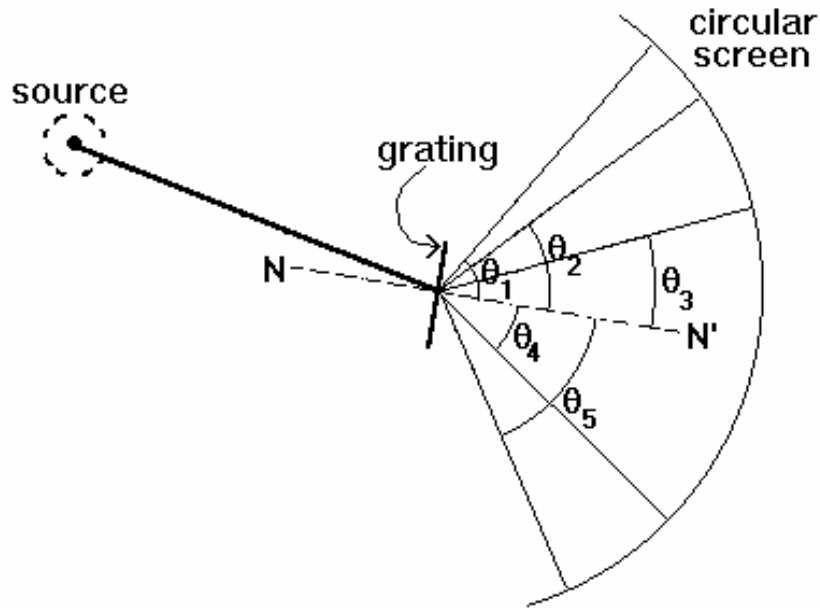

Figure 6

The angles θ_1, θ_2 etc. of the maxima from the line N - N' normal to the grating correspond to each of the component wavelengths making up the light from the source. By measuring these angles and using the grating equation, these wavelengths can be determined. This set of wavelengths is then compared with tables of known spectra to identify the elements present in the source. For precise measurements of very weak sources, a problem commonly faced by astronomers working with starlight, photographic paper, or more commonly nowadays: a extremely sensitive CCD array is placed on the screen and long time exposures are made.

In the lab we will study the visible spectra of several species of gas, using a diffraction grating to disperse light (as opposed to a prism which is often used). A plane wave (with wavelength λ) incident normally onto a diffraction grating (with spacing d) will be diffracted to angles θ given by

$$d \sin \theta = n \lambda ,$$

where $n = 1, 2, \dots$ is the “order” of the diffraction peak. Figure 1 shows the incident wave crests, which are planes where the wave is maximal. The wave is effectively re-radiated separately by each grating slit, forming circular wave crests as shown.

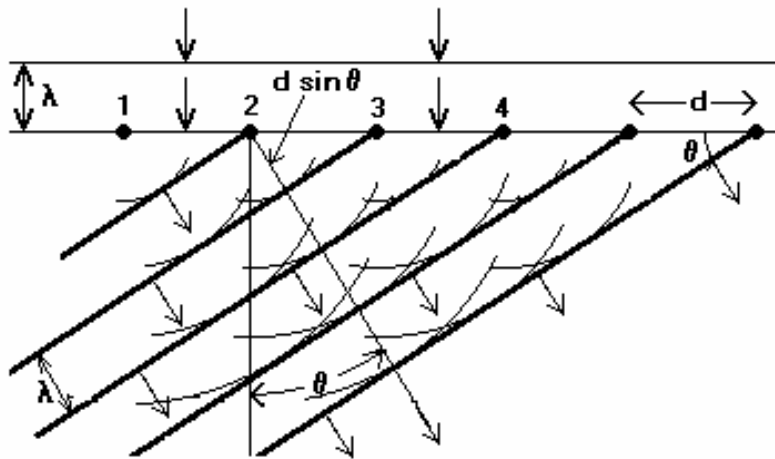

Figure 7

We see that the third wave crest from slit #1, the second from #2, and the first from #3 are coalescing to produce a new plane wave moving away at angle θ from the initial direction. One can see from the geometrical construction in the figure that this condition is satisfied if $d \sin \theta = n\lambda$.

Similar constructive interference occurs if $d \sin \theta$ is any multiple number of wavelengths, giving higher orders n .

If the plane wave is incident at an angle α with respect to the perpendicular to the grating, then the constructive interference peaks occur at angles θ given by

$$d \cdot (\sin \alpha + \sin \theta) = n\lambda \quad . \quad (\text{The grating equation})$$

A typical research-quality grating consists of a blank of glass upon which are engraved as many as 25,000 accurately parallel and evenly spaced grooves per inch of surface. This is an expensive process. Fortunately, it is not necessary to purchase an original grating in order to produce excellent spectra; "replica" gratings, made by molding plastic material against a good glass grating are nearly comparable in performance, and low enough in cost to be available to almost any experimenter. You will use a small replica grating with 25,000 lines per inch.

THE EXPERIMENT

Equipment

1. Samples of gases in glass “discharge tubes.” Some tubes contain a known gas (Hg or N or Ne) and three tubes contain “unknown gases” (labeled 1, 2, 3).
2. High voltage power supply to produce the electrical discharge within the sample tubes;
3. Diffraction grating with 25,000 lines per inch, i.e. $d = 1"/25,000 = 1.016 \mu\text{m}$
4. Grating support and marker for locating the spectral lines, both mounted so that their angular positions can be read on a scale;
5. Table of emission wavelengths (and strengths) for a few common elements, including the unknown gases.

DO NOT TOUCH the sample tube with the 5kV power supply ON.

Before mounting or changing one of the discharge tubes be sure that the power supply switch is off. The sample tubes have a small glass projection sticking out perpendicularly near one end. When changing sample tubes, be sure that this projection is at the top end of the tube. It is best to turn the supply off when not actually in use, to preserve the tubes which have a rather limited lifetime.

With the relatively bright discharge tube sources used in the lab, the observer's eye can be used as the detector, but this method restricts our measurements to the visible portion of the spectrum. The setup to be used in the lab is drawn in Fig. 2.

When you look through the grating illuminated by one of the discharge tube sources, you will notice a set of colored spectral lines, and the “marker” allows the angle ϕ to be measured. Each colored line corresponds to one of the components of the emission spectrum for the gas in the tube. The “first-order” set of spectral line images, corresponding to $n = 1$ in the grating equation, will be seen at the smallest angles ϕ (closest to the source itself). At larger angles ϕ you will probably see another set of lines similar to the first; this is the “second-order” spectrum corresponding to $n = 2$.

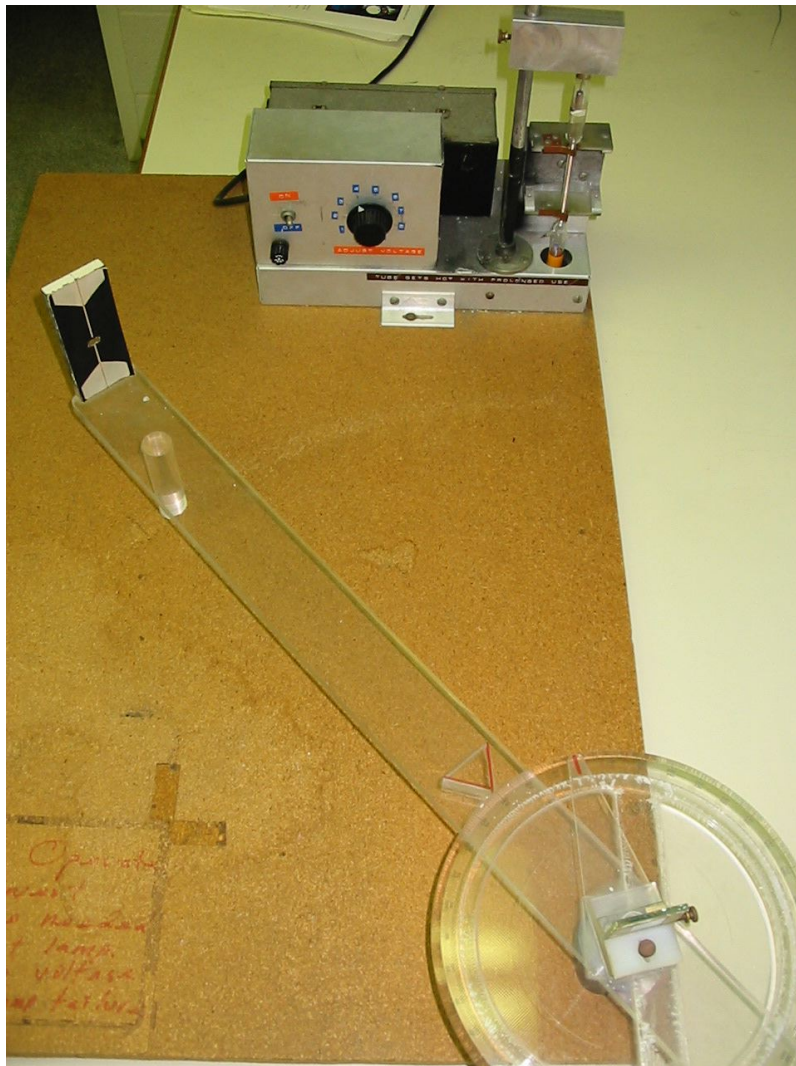
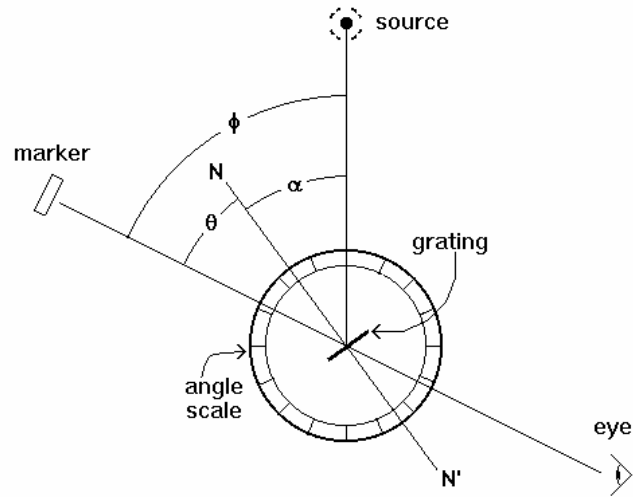

Figure 8

There are three angles in the apparatus: the grating angle α , the diffraction angle θ and the effective image angle $\phi \equiv \alpha + \theta$. The grating equation indicates that a given spectral line can appear at many different combinations of θ and α , but a particularly useful combination is one where $\alpha = \theta$. It is possible to show that the grating equation leads to

$$\frac{d\phi}{d\alpha} = 0 \text{ when } \alpha = \frac{\phi}{2} \text{ (i.e. } \alpha = \theta \text{);}$$

from calculus, we know that the setting where $\frac{d\phi}{d\alpha} = 0$ is the setting where ϕ is a minimum.

Thus, minimizing ϕ makes $\alpha = \theta$, and you need only measure the one angle ϕ . Simply rotate the grating while watching a particular color of the spectrum; and when that color has moved closest to the discharge tube (ϕ is a minimum), then you have found the place where $\alpha = \phi/2$ for that color. Then, move the marker to the color and measure ϕ .

We should also examine how slight inaccuracies in reading the diffraction angle ϕ will affect our determination of the spectral wavelengths. Taking $\alpha = \theta$, the grating equation for the first order spectrum is

$$2d \sin \frac{\phi}{2} = \lambda .$$

The uncertainty $\delta\lambda$ is related to our measurement uncertainty $\delta\phi$ by

$$\delta\lambda = \left(d \cos \frac{\phi}{2} \right) \delta\phi .$$

Roughly speaking, $\delta\lambda \approx d \delta\phi$. More accurately, $\delta\lambda$ will depend weakly on λ through the $\cos \phi/2$ factor. Consider, as an example, the midpoint of the visible spectrum ($\lambda = 550$ nm), and a grating with $d = 1.016 \mu\text{m} = 1016$ nm. Then for $\phi/2$ we have

$$\frac{\phi}{2} = \sin^{-1} \frac{\lambda}{2d} = \sin^{-1} .271 = .274 \text{ rad} = 15.7^\circ$$

and

$$\cos \frac{\phi}{2} = .96 ,$$

so

$$\begin{aligned} \delta\lambda &= (1016\text{nm})(.96)\delta\phi \\ &= (975\text{nm}) \delta\phi \\ &\equiv (975\text{nm}) \frac{2\pi}{360} \delta\phi_{\text{deg}} \\ &= (17\text{nm}) \delta\phi_{\text{deg}} \end{aligned}$$

Thus a 0.5 degree error in ϕ will produce a 8nm measurement error in a wavelength of 550nm; the $\cos \phi/2$ factor could actually be ignored in the error analysis.

You will notice that if you move your head while looking through the grating at a line, the line will appear to shift position slightly. This can introduce a significant error into your measurements. The grating has a mask with an arrow or line drawn on it parallel to

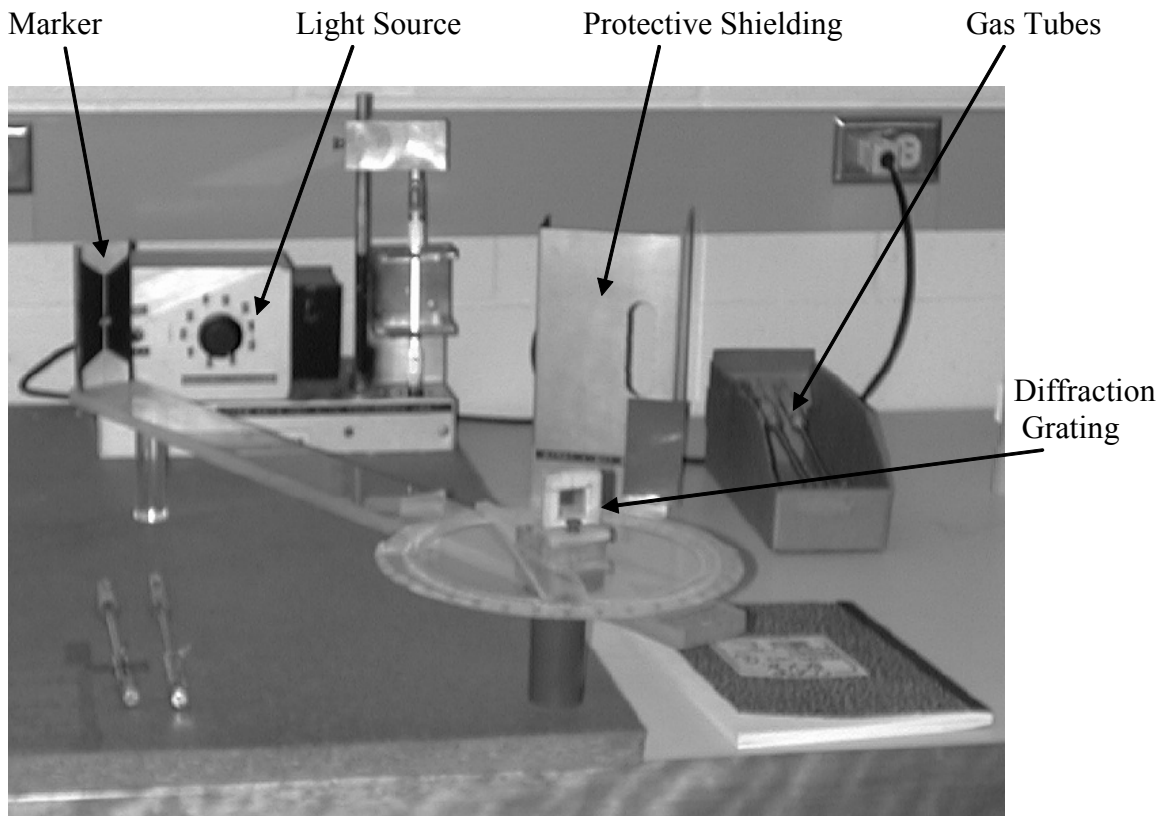

the grating rulings. If the grating is mounted so this line is on the axis of rotation of the marker arm, then

Figure 9.

you can eliminate the above uncertainty in image position by simultaneously lining up the image, the marker, and the line on the grating mask.

EXPERIMENTAL SETUP

The sample tubes have a small glass protection sticking out perpendicularly near one end. When changing sample tubes, be sure that this projection is at the top end of the tube, for otherwise you will not be able to put the tube into the high voltage socket of the power supply box without breaking it off.

Before mounting or changing one of the discharge tubes be sure that the power supply switch is off and that the power line cord is unplugged. Ask the laboratory assistant to show you how to change the tubes before attempting it by yourself. **This extreme caution is necessary because the 5,000 Volt output from the power supply could be lethal.** To avoid accidents it is best to turn the supply off when not actually in use. This also preserves the tubes, which have a rather limited lifetime.

CAUTION

- **Don't touch the sample tube with the power on or you may be electrocuted. Always use cloth to touch the sample tubes or you may burn yourself.**

- Stay under 5 kVolts to avoid over heating the sample.

Measurements and procedures to be done

1. Setup experiment as shown in Fig. 8 and Fig. 9.
2. Measure the optical spectrum of the 3 known tubes. This is done by placing the diffraction grating at a fixed angle α , for each set of spectra, and rotating the marker an angle ϕ for each individual spectral line. Measure the optical spectrum of the 3 known tubes. This is done by placing the diffraction grating at a fixed angle α , for each set of spectra, and rotating the marker an angle ϕ for each individual spectral line. Measure 5 or more separate lines for each gas [$j=1,2 \dots 5$]. For each line, make 4 separate measurements (2 each partner). Turn the grating to minimize ϕ , thereby making $\alpha=\phi$. Measure ϕ , estimate $\delta\phi$. Calculate λ , $\delta\lambda$, assuming $d = 1016\text{nm}$. Obtain $\bar{\lambda}_j \pm \delta\bar{\lambda}_j$.
3. Record the optical spectrum of the 3 unknown tubes in this same fashion. Make three sets of measurements of each tube to insure a more consistent value of error.
4. Observe the 2nd order spectrum from one of the discharge tubes (*either known or unknown*) and verify that the grating equation is satisfied for $n = 2$. Because the 2nd order spectrum is not as intense as the 1st, you may have to take special care to darken the room in order to see it.
5. *From the known spectrum*, calculate a calibration curve for the apparatus. A first step is to see if a constant must be added to or multiplied to your measured λ to obtain agreement with known spectra. This will lower the Systematic error in your measurements. However keep in mind other sources of Systematic error in this experiment.
6. Calculate the corresponding angle θ and the wavelengths for each set of measurements, including the experimental uncertainty of each, and identify the elements by comparison with the wavelength tables given at the end of these notes.
7. Address the following questions: What causes the emission, not just the spectral lines, from the tubes of gas? What are the major sources of systematic error and how could they be reduced in this experiment?

SOME PROMINENT EMISSION WAVELENGTHS FOR COMMON ELEMENTS

(Wavelength given in \AA)

H	He	Ne	A	I	Hg
3970	3889	4538	3948	3940	3650
4102	4471	4704	4044	4862	3663
4340	4686	4715	4159	5119	4047
4861	4922	4827	4164	5465	4358
6563	5016	4957	4191	6082	5461
	5876	5038	4345	6294	5770
	6678	5145	4510	6566	5791
	7065	5341	4596	6959	
		5400	4702		
		5764	5188		
		5852	5496		
		5882	5651		
		6030	5912		
		6074	6032		
		6143	6043		
		6163	6059		
		6217	6416		
		6267	6753		
		6402	6965		
		6506			
		6599			
		6929			
		7032			

TROUBLESHOOTING

- To insure the most accurate measurements maintain a constant eye level and position as any movement by your eye will result in large Systematic error.
- Because the secondary spectrum is weaker than the primary, darkening your work space will increase your ability to see the spectrum.

EXPERIMENT #2

Coherence of Light and the Interferometer

GOALS

Physics

- Measure the coherence length of light using an interferometer.
- Establish that “filtering” increases the coherence length.

Technique

- Use a Michelson Interferometer to measure the coherence length of filtered light from a mercury lamp.
- Use the interferometer to measure the coherence length and bandwidth of a ‘white’ light source.

Error Analysis

- Attempt to place an upper limit on $\Delta\lambda$ for the mercury green line by seeing how large $l_2 - l_1$ can be made with the fringes still visible.
- Is the coherence length you infer for the white light source consistent with what you already know about the bandwidth?

Question (Work out the following before coming to 2D lab) Yellow sodium light consists of two wavelengths, 5890 and 5896 angstroms. The interference pattern disappears and reappears periodically as l_2 is increased. What is $l_2 - l_1$ between two successive reappearances of the interference pattern?

Important Constants

$$\lambda_0 = 5291 \text{ \AA} \text{ for Mercury Light}$$

$$\lambda_0 = 5000 \text{ \AA} \text{ for White Light}$$

References

- Serway, Moses, Moyer §1.3
 - Tipler & Llewellyn §5.3
- Additional references:
- Giancoli, Physics for Scientists and Engineers, 2nd Edition
ISBN # 0-13-666322-2, pages 841-844
 - Halliday and Resnick and Walker; Fundamentals of Physics, 1st Edition
ISBN # 0-471-10558-9, page 917-918

BACKGROUND AND THEORY

In this experiment, we shall be concerned with light that is not strictly monochromatic (as is laser light), but rather consists of a mixture of wavelengths. Indeed, until the 1960's when the laser was invented, no perfectly monochromatic light had ever been seen or generated. Even the purest ordinary single-color sources (radiating atoms, for example) emit light that contains a spread of wavelengths.

A property of light that is directly related to its monochromaticity is its coherence. The degree of coherence of a source of light is the degree to which that light consists of long, unbroken trains of sinusoidal waves.

Suppose we have a train of pure sine waves with wavelength λ_0 having some total length $\Delta\chi$ in space, and propagating at velocity c .

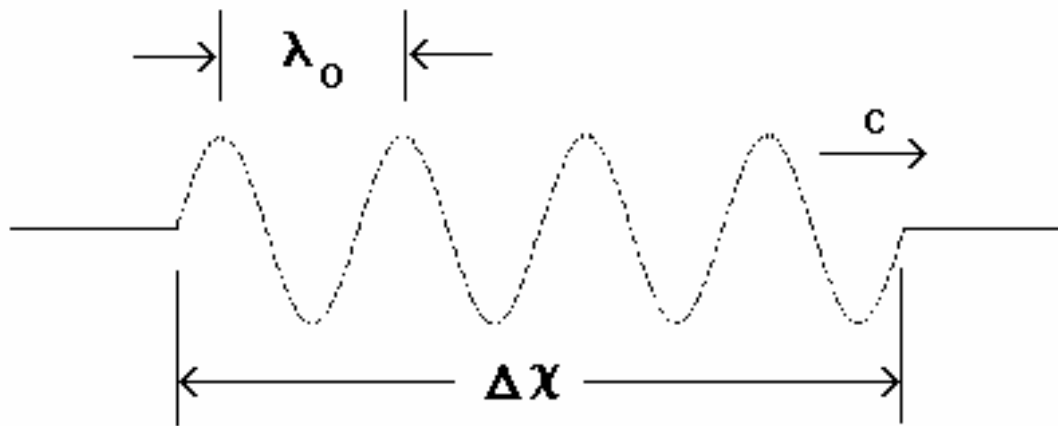

Figure 1

Mathematically, we might express this train in terms of the field seen by a stationary observer as the waves pass by:

$$E(t) = E_0 \sin w_0 t \quad , \text{ for } 0 < t < \frac{\Delta\chi}{c}$$

$$= 0 \quad \text{for } t < 0 \quad , \quad \text{or for } t > \frac{\Delta\chi}{c} \quad .$$

Now, we may inquire as to the frequencies present in this wave. Superficially, one might guess that here, we have only one frequency, w_0 , since the above equation seems to imply just that. This guess would be wrong, however, because the wave packet turns on and turns off, i.e., is not continuously oscillating.

The mathematical technique known as Fourier analysis deals directly with this problem. If we consider any arbitrary function $f(t)$, Fourier analysis shows us that it can be represented as a sum of simple trigonometric sine or cosine functions of different frequencies and different strengths. In particular, the Fourier Integral Transform takes our function $f(t)$ and converts it to a function $g(w)$ representing the strength of various frequencies in our original $f(t)$.

The simplest example is an infinitely long train of waves, i.e.

$$f(t) = E_0 \sin w_0 t, \text{ for } -\infty < t < \infty .$$

For this case, $g(w)$ is a "delta function", i.e., a single infinitely narrow peak at $w = w_0$, with no contribution anywhere else, indicating that here, there is indeed only one frequency (Fig. 2).

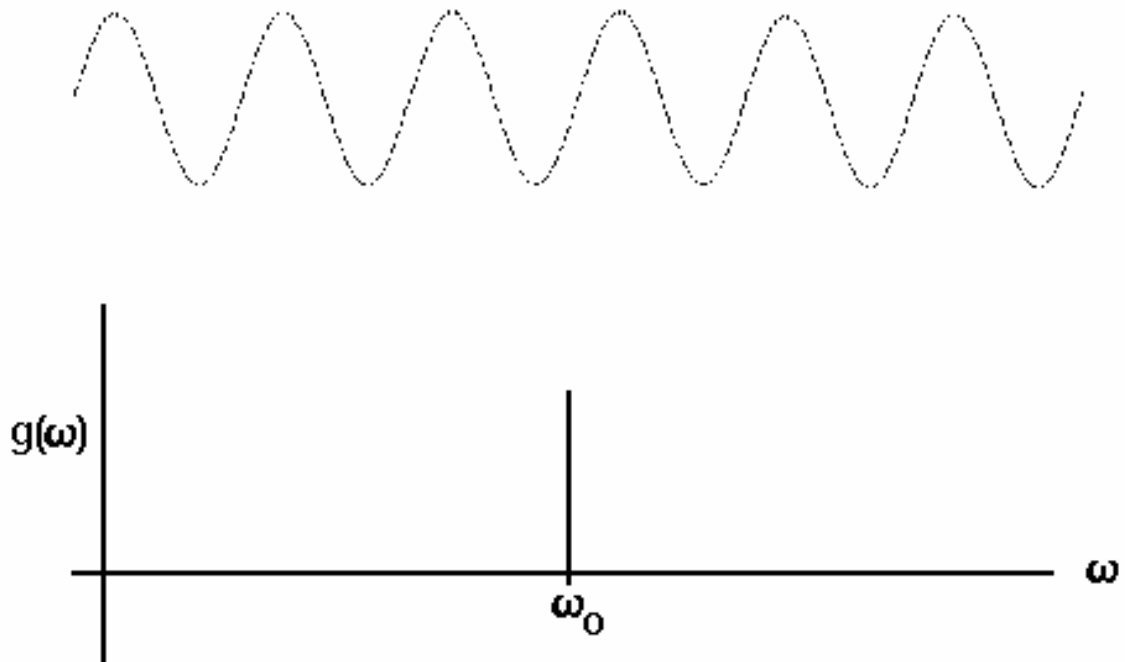

Figure 2

However, when we Fourier transform our short wave train of length $\Delta t = \frac{\Delta x}{c}$, we discover that a band of frequencies of width Δw has appeared in $g(w)$, centered at w_0 (Fig. 3).

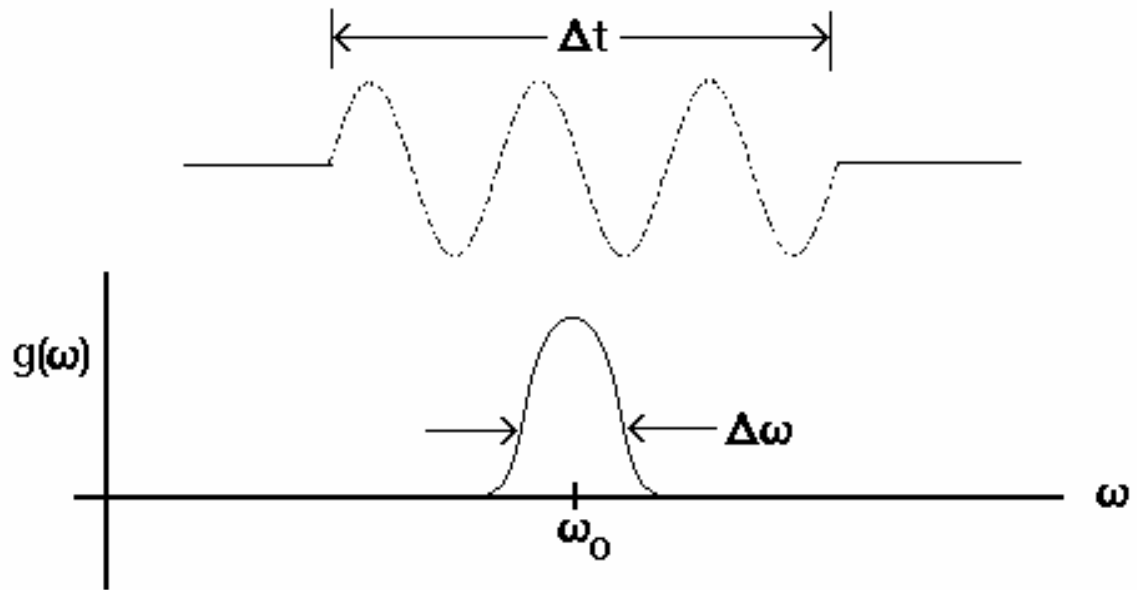

Figure 3

A general result, whose accuracy is sufficient for our needs here, is that a wave train of frequency ω_0 , truncated to a duration $\Delta\tau$ has its frequency spectrum spread over a range $\Delta\omega$, such that

$$\Delta\omega\Delta\tau = 2\pi .$$

Thus, a short wave "packet" contains a wide spread of frequencies, and a long packet has a narrow frequency spectrum.

This relation can also be cast in terms of the length Δx of the packet and the corresponding spread of wavelengths $\Delta\lambda$ around the central wavelength λ_0 . Since

$$\omega_0 = \frac{2\pi c}{\lambda_0} ,$$

and

$$\Delta\tau = \frac{\Delta x}{c} ,$$

we have

$$\Delta\omega\Delta\tau = \frac{2c}{\lambda_0^2} \Delta\lambda \cdot \frac{\Delta x}{c} = 2\pi ,$$

or,

$$\frac{\Delta\lambda}{\lambda_0} \frac{\Delta\chi}{\lambda_0} = 1 .$$

The spread of wavelengths $\Delta\lambda$ is also called the bandwidth, and the packet length $\Delta\chi$ is also called the coherence length.

THE MICHELSON INTERFEROMETER

The interferometer measures the coherence of light by making the light “interfere” with itself. A beam of light is passed through a partially transparent mirror, or "beamsplitter", so that every train of waves in the beam is split into two identical trains, each having half of the original intensity. Each wave train is sent along a separate path, after which the waves are again recombined. The two components will interfere destructively or interfere constructively, depending upon whether the difference in the path lengths is an even or odd number of half-wavelengths.

The Michelson interferometer, which we will use in this experiment, can be schematically described by the following figure:

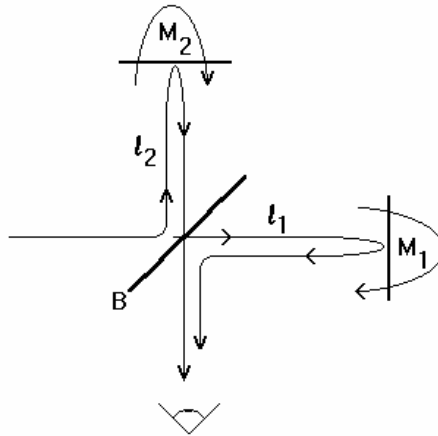

Figure 4

Part of the incoming beam reflects off mirror B and travels path length l_2 to mirror M2 and back; the wave-train which passes through B has path length l_1 . Some of each wave-train then travels to the eye. The eye will see darkness if

$$|l_2 - l_1| = (n + 1/2)\lambda_0 ,$$

and a bright light if

$$|l_2 - l_1| = n\lambda_0 .$$

A quite special situation arises, however, if we assume finite coherence length, i.e., partial coherence of the light.

First, consider the case where $\Delta\chi > (l_1 \text{ and } l_2)$. The beam consists of a random flood of wave packets, where all packets are much longer than paths l_1 and l_2 . When each packet recombines with its image at the output, it interferes with itself, and destructive or constructive interference will occur depending on $l_2 - l_1$.

Now, consider the case where $\Delta\chi < |l_2 - l_1|$; we get the situation in which one portion of the packet is delayed enough so that it fails altogether to overlap its partner at the output, and no interference can occur. That is, interference can not occur with a different wave of different frequency in the next packet.

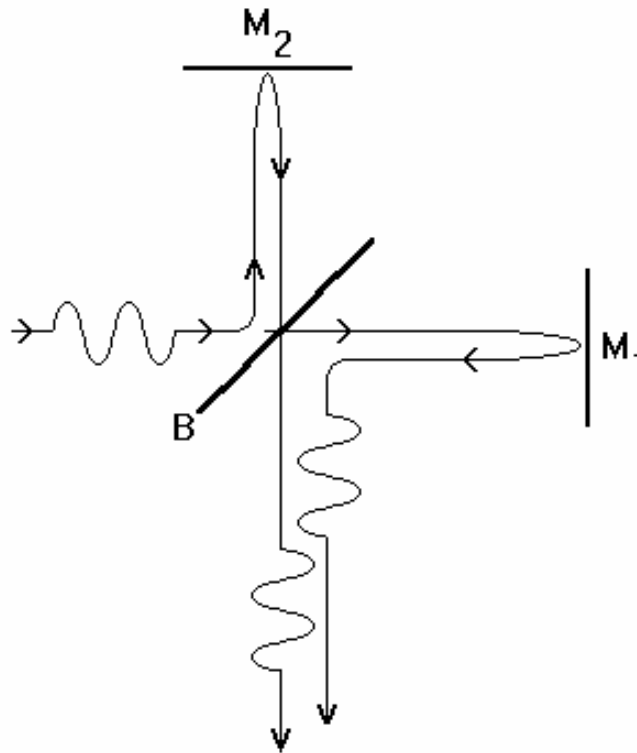

Figure 5

Thus, we have a convenient means of measuring coherence length: begin with $l_1 = l_2$, and increase l_2 until the alternating interferences become weaker and just disappear. $l_2 - l_1$ is then the coherence length Δx . This is the basic technique for this lab. $\Delta\chi$ is measured from center point to one limit rather than from limit end to limit end.

THIS EXPERIMENT

PURPOSE

The purpose of this experiment is to study the coherence length and band width of Mercury and White light using a Michelson Interferometer.

EXPERIMENTAL SETUP

Your instructor will acquaint you with the various components on the base of the instrument. The first mirror has two thumbscrews on the rear of its mount; these adjust the mirror angle so that the necessary condition of near perfect parallelism of the two beams can be achieved. These adjustments will have been set previously for you; don't touch them.

The second mirror is adjustable in distance from the beam splitter. You will notice a micrometer driving a lever arm that pushes on the mirror from a point near its fulcrum. The micrometer reading that gives $l_2 - l_1 = 0$ is marked on the base of the instrument.

** Micrometer Reading vs Δl **

The "micrometer" dial reads 0.00 to 25.00 *millimeters* of motion of the round shaft. The micrometer shaft actuates a *lever arm* which pushes the translation stage carrying the mirror (see Fig. 6 for details on round shaft and lever arm). Two full rotations of the lever arm are equivalent to 1 tic on the shaft. You can verify with a ruler that 20. mm (dial) = 4.0 mm (stage) = 8.0 mm (Δl). This gives

$$\begin{aligned} 1 \text{ mm (dial on lever arm)} &= 400. \mu\text{m} (\Delta l) \\ \text{or} \\ 1 \text{ tic (dial on round shaft)} &= 4. \mu\text{m} (\Delta l) \end{aligned}$$

The light source you will use for the first part of the experiment is mounted on a bracket that extends from the main base. It contains two sources, each controllable from the switch box. One is an ordinary white incandescent bulb that emits at all visible wavelengths. The second is a mercury vapor bulb that emits light at a few discrete wavelengths; we say that these are "lines" in the violet, blue, green, and weakly in the yellow.

Included also in your equipment are two filters that transmit light over wavelength bands of different width. The green plastic filter transmits a much wider band than the blue filter; you will determine their approximate bandwidths, $\Delta\lambda$, in this experiment.

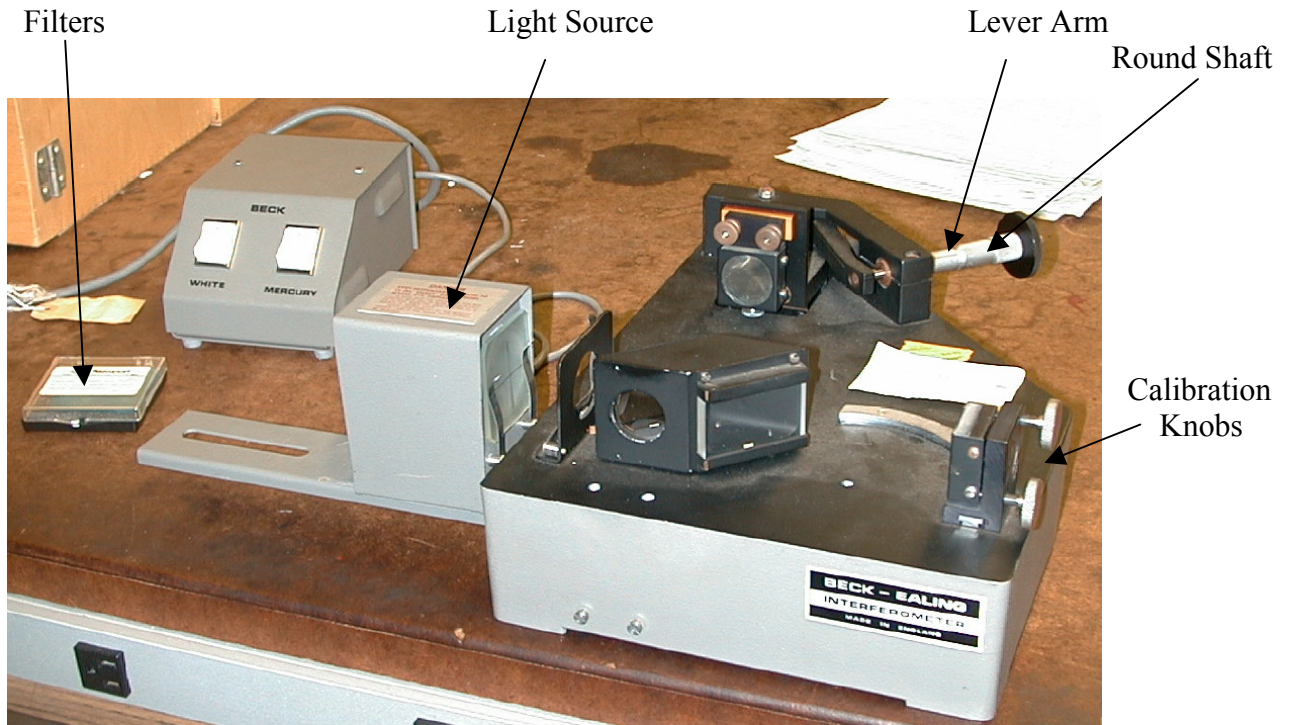

Figure 6

CAUTION

- The Michelson Interferometers you will use in this laboratory are precise and expensive research-grade instruments. They must be handled with great care, since the dimensional tolerances that have to be maintained are on the order of a wavelength of light, or a few times 10^{-5} cm.
- Be particularly careful not to touch the mirrors or beam splitter. The mirrors are coated on the front surface, so they are particularly susceptible to damage.
- Be careful not to touch the calibration knobs associated with the first mirror. Moving these knobs will eliminate any visibility to the fringes.

PROCEDURE

1. Turn on the mercury lamp, and slip the green filter over its window. The filter will pass the green spectral line while blocking the other lines. The spectral width $\Delta\lambda$ of the green light that passes through the filter is not determined by the filter, but rather by the mercury atoms themselves, which produce an extremely narrow bandwidth and a very long $\Delta\chi$.
2. Assuming that the interferometer is in proper adjustment, you should be able to see in the viewing port a series of vertically oriented stripes, or "fringes". The reason that you see several fringes rather than a uniform illumination over the field of view is that the image of mirror M_1 is not exactly parallel to M_2 .

this is similar to the infinite series of images of yourself that you can see in a “house of mirrors” or some bathrooms! Our analysis presumed that both mirrors are perpendicular to the light path. Actually each mirror has some small angular deviation from perpendicularity. Thus, the difference in path lengths $l_2 - l_1$ varies from one point on the mirror to the other.

3. Ask your TA to make a slight adjustment in the nearest screw on M_1 in order to adjust the angle of that mirror. **Please do not make these adjustments yourself as you are not yet familiar with the calibration of the machinery.** Note that the number of fringes in the field of view can be set to any value you please.
4. Now, with about ten fringes or so in the field, make a slight adjustment of $l_2 - l_1$ with the micrometer. For each complete fringe that passes a given point in the field, $l_2 - l_1$ has changed by λ_0 . Estimate λ_0 from the fringe motion versus dial tics. Why does the fringe pattern appear to move across the field?
5. Attempt to place an upper limit on $\Delta\lambda$ for the mercury green line by seeing how large $l_2 - l_1$ can be made with the fringes still visible. The upper limit of the fringes is determined by a closed circular fringe.
6. Next, turn on the white light, and remove the green filter. You will see no fringes at all until you adjust $l_2 - l_1$ to the neighborhood of zero, and then make a very careful search. Go slowly; the few fringes are easy to miss. Determine how large $l_2 - l_1$ can be with the fringes still usable.
7. What can you conclude about the coherence length of white light from the fringes you see? Is the coherence length you infer consistent with what you already know about the bandwidth?
8. Place the green filter over the white light, and re-estimate coherence. Notice that visually, the present green light and the mercury line are the same, but that their coherences are very different.
9. Now, substitute the blue filter. Infer its bandwidth from the maximal $l_2 - l_1$ for fringes.

TROUBLESHOOTING

- The Mercury light has a very long coherence length which trails off indistinctly; therefore, take note of what you read as the end point and why you chose this as the end point. We recommend the point where one complete circular fringe is visible in the screen.
- If you cannot see any fringes at all or they are very faint and tiny, ask your TA to adjust the calibrations properly for you.

EXPERIMENT #3

The Photoelectric Effect

GOALS

Physics

- Measure Planck's constant by using the photoelectric effect.

Technique

- Use the oscilloscope and a vacuum photodiode to find "cut-off" energy of photoelectrons.
- Appreciate the "reverse" current problem in the photodiode.
- Graph photo-electron "cut-off" energy vs. photon frequency in a way which shows the "work function" and allows you to find Planck's constant h .

Error Analysis

- Use allowable slope fits to your data points to estimate the accuracy of h .
- Compare your value of h to the accepted value.

Question (work out the following before coming to 2D lab)

- Suppose that you have applied 1 volt between the anode and cathode of the photodiode and that 99% of the electrons from the cathode are prevented from getting to the anode. If there are 100 times as many electrons being kicked out of the cathode as there are from the anode, what is the anode current which you see on the oscilloscope)? Does this correspond to the "cut-off" voltage?

Notes:

- Read the oscilloscope manual provided on the 2DL website to familiarize yourself with its operation.
- Familiarize yourself with all the warnings for this experiment in this lab manual.

Important Constants

$$c = 3 \times 10^8 \text{ m/s}$$

$$e = 1.6 \times 10^{-19} \text{ coul}$$

$$h = 6.64 \times 10^{-34} \text{ J} \cdot \text{s} = 4.15 \times 10^{-15} \text{ eV} \cdot \text{s}$$

References

- Serway, Moses, Moyer §2.4
- Tipler & Llewellyn §3-3

Additional References:

- Giancoli, Physics for Scientists and Engineers, 2nd Edition ISBN # 0-13-666322-2, pages 880-885
- Halliday and Resnick and Walker; Fundamentals of Physics, ISBN # 0-471-10558-9, page 172

BACKGROUND AND THEORY

The photoelectric effect describes the ejection of electrons from matter by incident electro-magnetic radiation, particularly visible light, ultra-violet light, and x-rays. At the time of the discovery of this effect in the late nineteenth century, it was mysterious; indeed, the observations contradicted much of what was known about electromagnetic waves. In the end a considerable expansion and improvement, rather than a demolition, of classical physics took place. This phenomena is ubiquitous - photoelectric emission from carbon 'dust' grains is the most important heating mechanism of interstellar gas clouds, for example.

One of the first published observations of the photoelectric effect was by Heinrich Hertz. While conducting some of his monumental experiments on electromagnetic waves in 1887, Hertz noticed that the gap between a pair of oppositely charged electrodes broke down, or sparked, quite readily when a second spark gap was fired in the immediate neighborhood. He verified that ultra-violet radiation was ionizing the first gap and causing it to break down.

Subsequent research by others in the next few years produced the following results:

- A) A clean, insulated zinc plate was found to become positively charged when illuminated with ultra-violet light -- even in a vacuum -- and a negatively charged plate lost its charge when so illuminated. (W. Hallwachs, 1888)
- B) The electron had been identified during this era, and its charge-to-mass ratio was measured by J. J. Thomson. It was shown that the acquisition of positive charge (and the loss of negative charge) by irradiated plates was in fact due to electron ejection. (P. Lenard, 1900)
- C) The first observation of the photoelectric effect was announced by J. Elster and H. Geitel in 1900. Their apparatus consisted of a pair of plates in a vacuum, one of which was illuminated. The second plate was positively charged, and thus attracted the (negative) electrons to itself. This transfer of electrons between plates was observed as an electrical current in an external circuit. It was shown that the electrical circuit current, and hence the number of photo-electrons ejected per unit time, is exactly proportional to the intensity of illumination. One may express this as

$$N = \alpha I,$$

where N is the number of electrons emitted per second, and I is the intensity of the ultra-violet light. The constant α depends on the material of the electron emitting plate, or photocathode, its surface condition, and the wavelength and angle of incidence of the light.

- D) In 1902, P. Lenard discovered the second, and most astonishing law of the photoelectric effect: the maximum energy of the emitted electrons depends only

on the wavelength of the ultra-violet illumination, not on the intensity of illumination. This contrasts sharply with the predictions of classical electromagnetism. (Question: how does this contradict “classical intuition”?).

You will recall that an electromagnetic light wave consists of oscillating electric and magnetic fields at right angles to each other; and these fields are also perpendicular to the direction of propagation of the wave. The intensity, I , of the wave is proportional to the square of the electric (or magnetic) field strength, i.e.,

$$I \propto E^2 .$$

(Question: where does this relation come from and can you relate it to power in electrical circuits?). It is reasonable to suppose that the electric field, \vec{E} , is what tears the electron loose from the metal surface. Therefore, it is reasonable to expect that the speed of the ejected electrons should be greatest for the most intense irradiation.

Lenard measured these electron speeds by applying a small negative, or repelling, voltage to the collector plate in his apparatus. We illustrate the principle in Fig. 1.

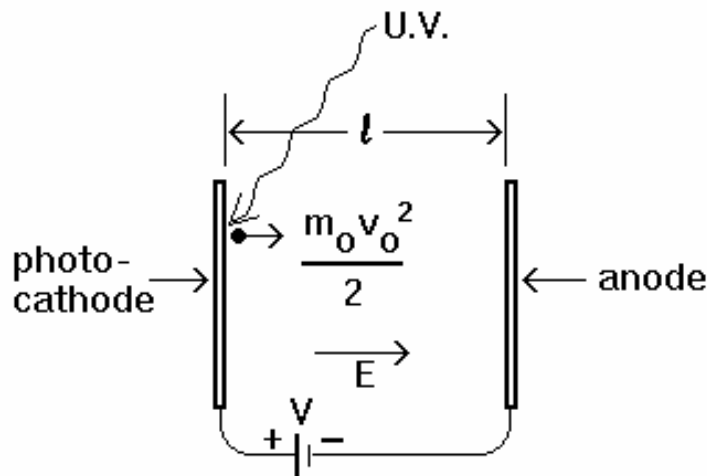

Figure 1

Suppose an electron is ejected from the cathode with a kinetic energy $K = \frac{1}{2} m v_0^2$. The

applied voltage V causes an electric field, $\vec{E} = V/l$, which gives a decelerating force on the electron,

$$\vec{F} = -e \vec{E} .$$

The electron does work in moving against the force, and this work comes out of its kinetic energy. Thus,

$$\Delta W = -\Delta\left(\frac{mv^2}{2}\right) = \int F dx.$$

Therefore, when the electron reaches the anode,

$$\begin{aligned} \frac{mv^2}{2} &= \frac{mv_o^2}{2} - e \int_o^l E dx \\ &= \frac{mv_o^2}{2} - eV, \end{aligned}$$

since $V = \vec{E} \cdot \vec{l}$.

Clearly, the electron will be turned back before it reaches the anode if

$$eV > \frac{mv_o^2}{2}.$$

Thus, we have a means for measuring electron kinetic energies: simply apply a retarding potential and measure the resulting circuit current. When the current just disappears, we have applied a voltage corresponding to the most energetic electrons. This means of measuring charged particle energies (and also of accelerating, rather than decelerating them) is so common that it is now universal practice to specify particle kinetic energies in electron volts. An electron which is just stopped at the anode of the apparatus by a one volt retarding potential had an initial kinetic energy of one electron volt (eV).

Lenard used this procedure to determine the distribution of electron energies from a photocathode. He obtained a most surprising result, which was that the maximum electron kinetic energy depends only upon the wavelength of the irradiation and is completely independent of its intensity. Interestingly, Lenard was a bitter foe of Einstein and rejected the theory of relativity.

E) The dependence of maximum electron energy on wavelength λ was found to be extremely simple (Millikan, 1916). It is stated most simply in terms of the frequency ν of the light, which is

$$\nu = \frac{c}{\lambda},$$

where c is the velocity of light ($= 3.0 \times 10^{10}$ cm/sec). The observed maximum energy eV_0 was observed to increase with light frequency ν , but the light frequency needed to be at least ν_0 to get any electron emission at all! This is shown in Fig. 2.

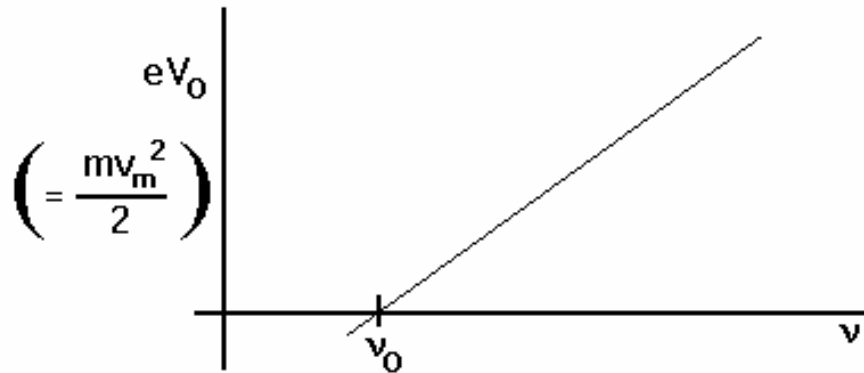

Figure 2

The data fits a straight line of the form

$$eV_0 = h(\nu - \nu_0) ,$$

or,

$$eV_0 = h\nu - W_0 .$$

This final equation is known as the “Einstein relation,” because it was announced by Einstein in 1905 on purely theoretical grounds, the year Lenard won the Nobel Prize for Physics!

Einstein’s main supposition was based on an earlier idea of Max Planck, the interchanges of energy between matter and radiation occur in discrete bundles or quanta of energy. Each quantum was asserted to contain energy W in proportion to the radiation frequency, i.e.,

$$W = h\nu \quad ;$$

the constant h has ever since been known as Planck's constant. The Einstein relation, $eV_0 = h\nu - W_0$, equates the kinetic energy of an ejected electron to the photon energy less the energy W_0 required to get the electron out of the material. W_0 depends upon the material and condition of the photocathode, but the constant h is always the same.

What is also implied is that unless the frequency ν is greater than $\nu_0 \equiv W_0/h$ for the particular material, no photoelectrons will be ejected. This is found to be precisely

true. The “work function” W_0 varies greatly from one substance to another. For the alkali metals, photoelectrons can be produced by visible light; thus, photocathodes containing cesium are commonly used on vacuum photocells such as the one you will use in this experiment.

F) From the form of the Einstein relation, one might surmise that a light wave has at least some of the attributes of a particle whose kinetic energy is $h\nu$, and which somehow collides with the electron, knocking it loose. It turns out one other important observation lends great strength to this idea: classical electromagnetic theory suggests that very weak illumination should have to “accumulate” for some time before an electron is emitted, but no delay is observed – the photoejection is said to be “prompt”.

The wave theory of radiation says that the energy flux (i.e., the wave energy passing through unit area normal to the beam each second) is uniform over a plane wave front, and that this flux is a direct measure of the intensity; it varies as E^2 , i.e. continuously, as mentioned above.

Now, with some information about the density and atomic weight of the cathode, and also about the depth of penetration of the radiation, suppose we make an order-of-magnitude estimate of the number of electrons on each square centimeter of the cathode which are available for ejection. If this number is, say, n_s electrons per cm^2 , then each electron can receive its share of the wave energy from an area no bigger than $1/n_s \text{ cm}^2$.

Suppose we have a light intensity of I (in $\text{Joules}\cdot\text{m}^{-2}\cdot\text{sec}^{-1}$); that is, I Joules of energy enter 1 square meter of surface in 1 second. Suppose also that I estimate that n_s electrons per square meter are “available” to be ejected near the surface.

$$I \text{ ergs cm}^{-2} \text{ sec}^{-1}$$

Then, each electron can get energy no faster than

$$I/n_s (\text{Joules}\cdot\text{sec}^{-1}) .$$

Then, in order to accumulate W_0 Joules and get out, the electron has to accumulate energy for a time

$$\tau = \frac{W_0 n_s}{I} \text{ seconds.}$$

However, it has always been observed that the time delay between the start of illumination and the appearance of photoelectrons is immeasurably short, even when τ , as estimated above, is many days.

We conclude that the light energy is not uniformly observed over the entire surface, but rather highly concentrated at particular points.

These 3 observations compel us to accept the idea that light really consists of small quantized packets of energy, called photons, each of which carries energy $h\nu$. The light intensity is then the flux, or stream density, of these particles; hence, the photoelectric current is exactly proportional to light intensity. The energy of ejected electrons is independent of intensity, since a particular electron is ejected by only one photon. Furthermore, the observed one-photon-per-photoelectron also makes the duration of the ejection process quite independent of the photon flux.

However, there still remains a great dilemma concerning the nature of light. The photoelectric phenomena absolutely require photons, but other observations, such as the diffraction and interference of electromagnetic radiation are only sensible in a wave picture. This “duality” is central to the highly successful quantum theory which was developed after 1925, but it remains a tantalizing intellectual puzzle to this day.

Rather than constructing the electrode system and placing it in a cumbersome vacuum system, however, you will use a simple commercial two-element phototube. Surprisingly, you will be able to arrive at a reasonably close determination of Planck's constant, h , with very simple equipment.

PHOTOELECTRIC EFFECT EXPERIMENT

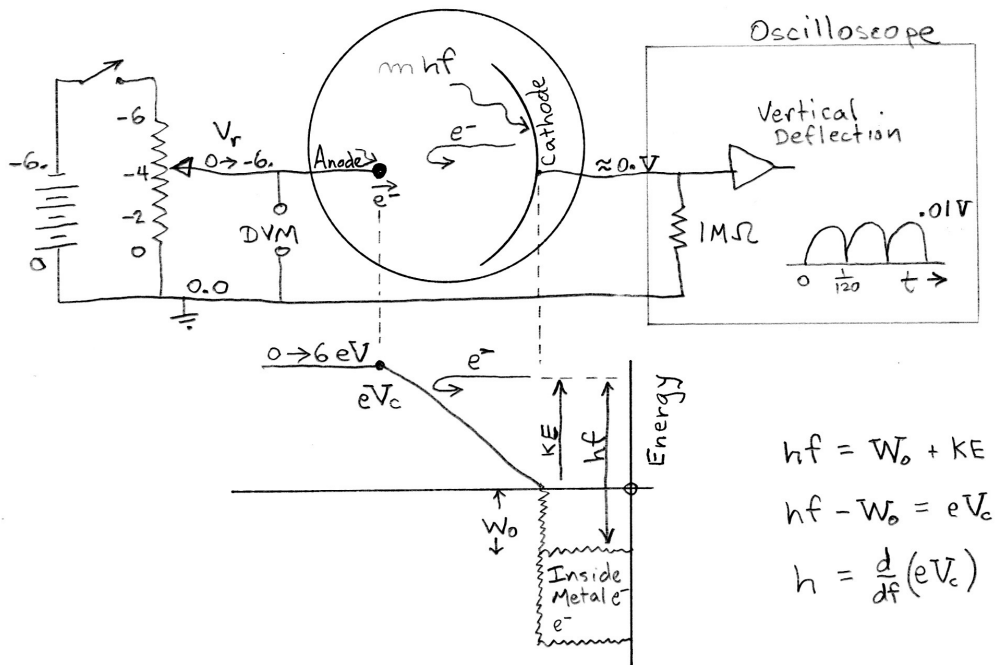

You will use a mercury discharge lamp to produce the radiation which photo-ejects electrons from the metal anode. The wavelengths in Angstroms ($1 \text{ \AA} = 10^{-10} \text{ m}$) of the prominent lines of mercury are as follows:

5770
 5461 (green)
 4358 (blue)
 4047 (violet)
 3650
 3132 (ultraviolet)
 2537

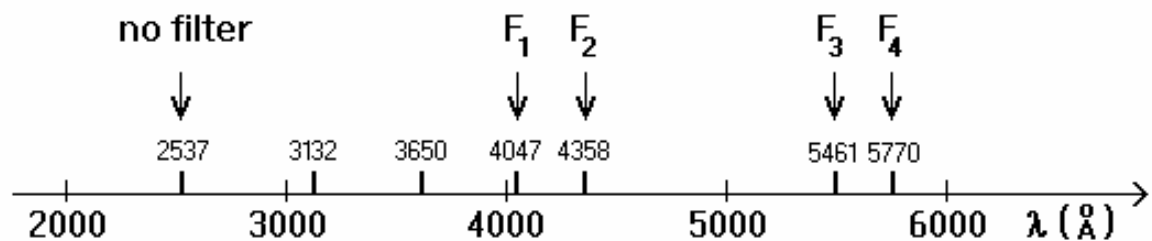

Figure 3

The arrows in Fig. 3 indicate the wavelengths that are passed by special filters (F_1 to F_4) you can place in a holder on the mercury light housing. These "interference" filters pass only wavelengths within about 50 \AA of the wavelength marked on the edge of the filter. They thus permit the selection of 4 specific mercury emission lines. The wavelengths, λ_m , indicated on the filters correspond to light incident at $\theta = 90^\circ$. At other angles, the wavelengths passed by the filter becomes $\lambda_m / \cos(\theta)$. This means that a 10° tilt/misalignment is likely to cause difficulties.

You will recall that Lenard's method was to apply a retarding voltage V between the electrodes until the current flowing from the anode through the 1Megaohm resistor back to the cathode stopped, so that

$$eV = \frac{m_e v_{\max}^2}{2}$$

But these fastest electrons are produced by the highest frequency, or shortest wavelength illumination, and it will make no difference if longer wavelengths are also present. Therefore, if we employ no filters over the lamp, the 2537 \AA line will determine the "cutoff" voltage.

Channel 1 of your oscilloscope will be used as an indicator of photo-cell current. Since the scope input resistance is 1 MegaOhm (10^6 ohms), the voltage you read on screen will be one volt for each microampere (10^{-6} ampere) of current. The variable resistance voltage divider allows the application of retarding potentials between zero and 4.5 volts to the cathode. You can easily show from Fig. 4b that

$$V_{\text{Out}} = \frac{R_2}{R_1 + R_2} V_{\text{batt}}$$

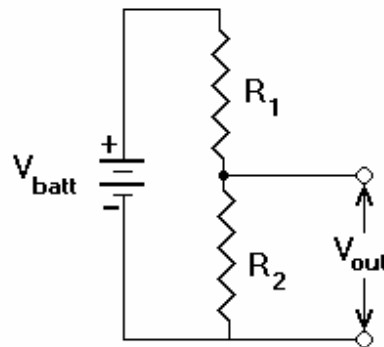

Figure 4

so by varying the ratio R_1/R_2 you can vary V_{out} from zero to V_{batt} . The second of the 2 scope channels is used to measure V_{out} .

THE EXPERIMENT

PURPOSE

To verify the photonic nature of light and measure the value of Planck's constant h by observing the relation between the light frequency used to induce photoemission and the energy of the electrons emitted.

EQUIPMENT

1. Mercury discharge lamp;
2. photosensitive vacuum tube;

3. set of light filters;
4. circuit to produce retarding voltage across phototube;
5. oscilloscope – read oscilloscope manual on 2DL website before coming to lab.

The light source is a mercury discharge lamp whose light is concentrated at a few discrete wave-lengths. It is customary to designate these narrow wavelength bands as "lines", since on a spectrograph they appear as bright lines whose positions correspond to their wavelengths.

At this point in your preparation you should make certain that you can obtain a numerical value of Planck's constant from a graph of cutoff voltage in Volts versus maximum light frequency in Hz. Be especially careful about your units when calculating Planck's constant.

The mercury lamp is operated from the 60 cycle power line, so its intensity peaks 120 times per second. The number of photoelectrons ejected per second is proportional to the intensity of the light, so the photocurrent in your circuit will also peak 120 cycles per second. When you increase the retarding voltage by turning the voltage divider knob on top of the phototube enclosure, you will notice that the amplitude of the 120 cps negative peaks decreases, reaches zero, and becomes positive peaks at still larger values of the retarding voltage. This unexpected observation is caused by photoelectrons emitted from the anode instead of the cathode. The number of anode electrons is kept small by shielding the anode from the direct light of the mercury source, but we cannot control reflections within the tube itself.

The anode electrons are accelerated rather than decelerated by the voltage applied to the tube; and therefore, even when the cathode's photoelectrons are completely stopped by the retarding voltage, there will still be a non-vanishing anode electron current in the opposite direction. Since essentially all of the anode electrons are collected at the cathode for even very small "retarding voltages" across the tube, the residual current contributed by them should be independent of small changes in the voltage. Thus, the value of the retarding voltage when the total current (anode plus cathode electrons) ***just ceases to vary with voltage is the value which just prevents the most energetic of the cathode electrons from reaching the anode.*** This unfortunate experimental complication makes the exact location of the cutoff voltage difficult to find unless you are very careful.

A good procedure is to plot the current, I , versus retarding voltage, V , to determine the cutoff voltage V_c :

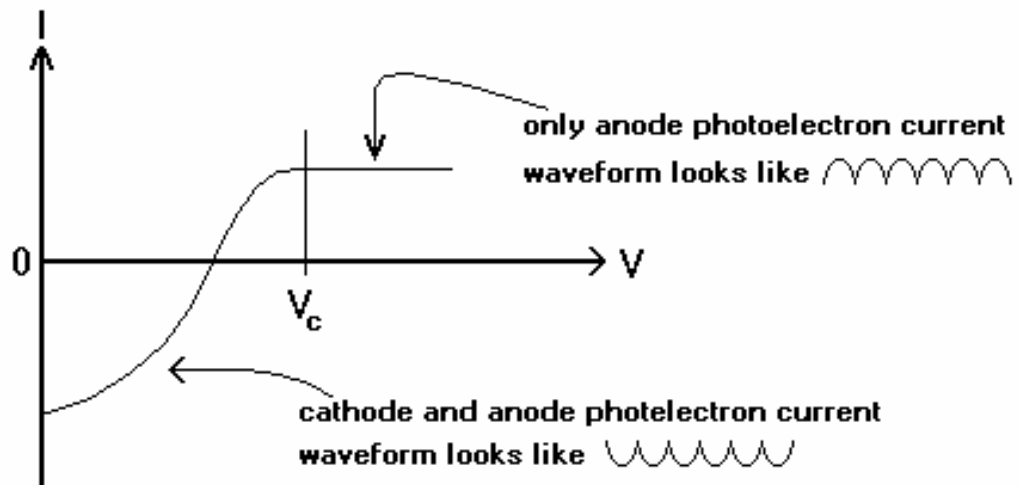

Figure 5

Only the region around V_c needs to be plotted. Note that the voltage at which the amplitude is zero corresponds to the point where the number of electrons reaching the anode happen to exactly match the number of anode electrons which are leaving the anode and is therefore of no particular interest.

You will probably wish to open the metal box which contains the phototube and battery, and examine it more closely. **Please do so carefully – inspect only, don't touch either the tubes or the circuit components. They are very delicate!** The semi-cylindrical electrode is the cathode, and the tin rod is the anode. A piece of tape on the tube envelope shields the anode rod from the light. When you replace the tube, make sure you rotate it so the anode cannot be seen through the entrance aperture. The metal box and shielded cable to the oscilloscope are necessary to prevent interference from nearby power circuits in the building.

The light source is started by first setting the toggle switch to start and pressing the red start button; then the toggle switch must be set to operate, or else the life of the discharge tube will be greatly reduced. The battery switch is located on top of the phototube box. Be sure that this switch is turned off when you are through with the measurements.

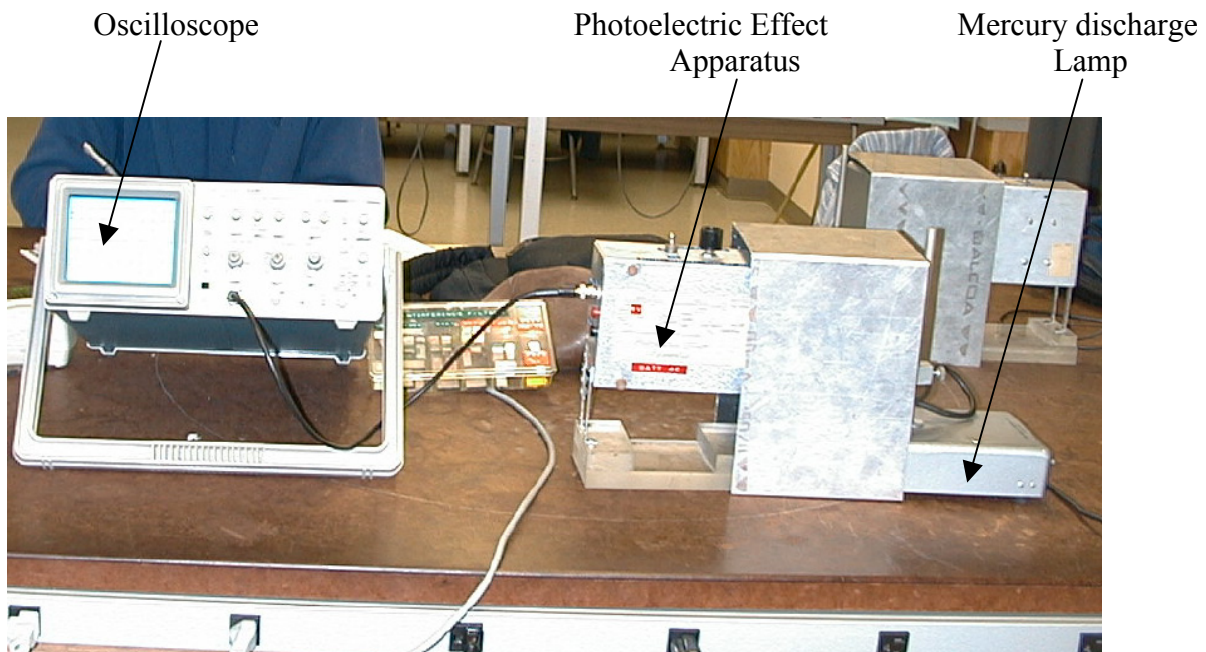
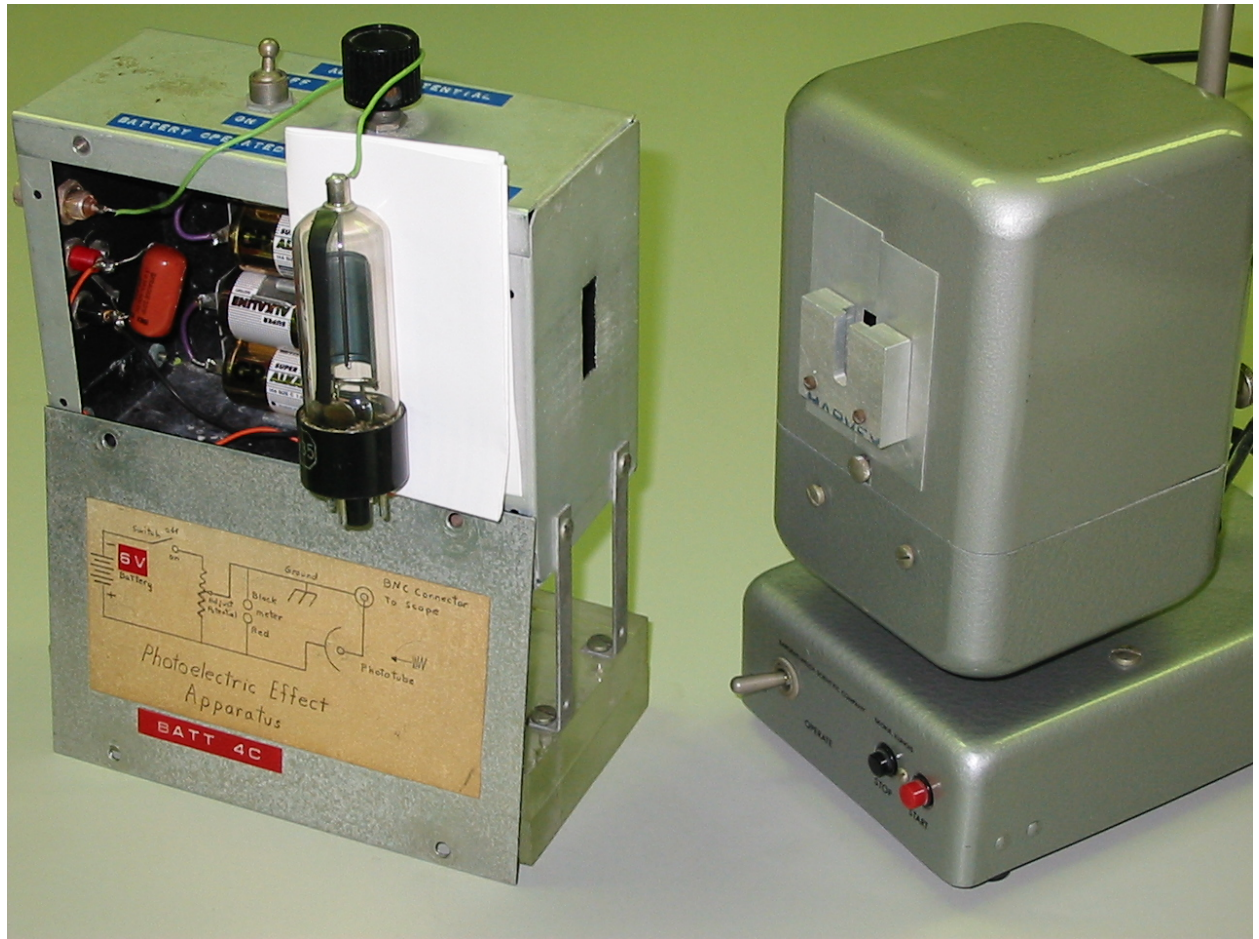

Figure 6

CAUTION

DO NOT LOOK DIRECTLY INTO THE DISCHARGE TUBE WHEN THE LAMP IS OPERATING since ultra violet radiation damages the unprotected eye. Place the light source and phototube housing an inch or so apart and cover both with the light shield hood. This shield hood is necessary to keep the room light out of the cell. (Fluorescent lights also contain the mercury spectrum.)



PROCEDURE

1. Turn on the oscilloscope, the lamp, and the apparatus. To turn on the lamp, press down on the RED button and move the switch to OPERATE. Move the signal to center screen by adjusting the 'position' knob, and insure that you are triggered – see the oscilloscope manual provided on the 2DL website. Adjust potential on apparatus to V_0 .
2. Measure the cathode electron cutoff voltage V_c without using a filter. The measurement without a filter refers to the V_c with the highest frequency. V_c is measured by increasing the voltage from V_0 to the exact point when the wave form flips orientation and reaches its maximum.
3. To put in a filter you must first switch the apparatus off, and the lamp off by pressing the BLACK, “stop” button. Then place a filter in the small slot in front of the lamp using needle-nose pliers provided, so as not to tarnish the filter with your fingerprints.
4. Measure the cathode electron cutoff voltage V_c for each of the four filters shown in Fig. 3. Make about 4 determinations of the cutoff voltage for each filter and also without the filter to get an idea of reproducibility.

5. Find the highest frequency present in the light for each filter and plot your measured cut off voltage V_c as a function of the maximum light frequency ν on a piece of graph paper. Each data point on the graph should have error bars indicating the precision of your measurements. Draw an average straight line through your data and from this line determine Planck's constant. The uncertainty in your result can be obtained by noting the range of different lines you can draw through your data.
6. How does your result for h compare with the commonly accepted value? Can you give a plausible explanation of any disagreement? Include error analysis and present results in the correct form (significant figures, units, etc).
7. Give a two-line description of the “Fermi Sea”.
8. What are the dominant sources of systematic errors in this experiment and how could they be reduced?

TROUBLESHOOTING

- If wave form will not flip orientation, take V_c to be point where wave form no longer responds to ΔV .
- If no wave form shows up, change the distance between the lamp and the apparatus (**don't do this while apparatus is powered – you might look into the UV radiation**). You may be at a diagonal instead of straight on (tilt misalignment) and/or the intensity is very sensitive to distance.

EXPERIMENT #4

Charge to Mass ratio of the Electron

GOALS

Physics

- Measure the charge-to-mass ratio e/m for electrons.

Technique

- A low pressure He-gas-filled tube allows the electron trajectories to be seen by eye.
- Helmholtz coils produce a uniform magnetic field.

Errors

- You should calculate your best estimate for $e/m = \bar{x}$ and your “standard error” $\sigma_{\bar{x}}$ as

$$\sigma_{\bar{x}} = \sqrt{\frac{\sum_{i=1}^n (x_i - \bar{x})^2}{N(N-1)}} \text{ from your } N \text{ measurements } x_i \text{ of } e/m.$$

Question: Which causes a larger systematic error in your e/m measurement:

- (a) a 5% error in V , the acceleration voltage; or
- (b) a 2% error in z_0 , the separation between the coils of the Helmholtz magnet?

References

- Serway, Moses, Moyer §3.2
- Tipler & Llewellyn §3-1

THE EXPERIMENT

The e/m tube to be used in the lab contains an electron gun to produce a beam of electrons, a very low pressure helium vapor atmosphere to render the beam visible, and a glass scale to permit measurements of the trajectory of the electrons. The simple electron gun is pictured schematically in Fig. 1. The gun has a hot filament, which serves as the emitting cathode, along the axis of the cylindrical anode can.

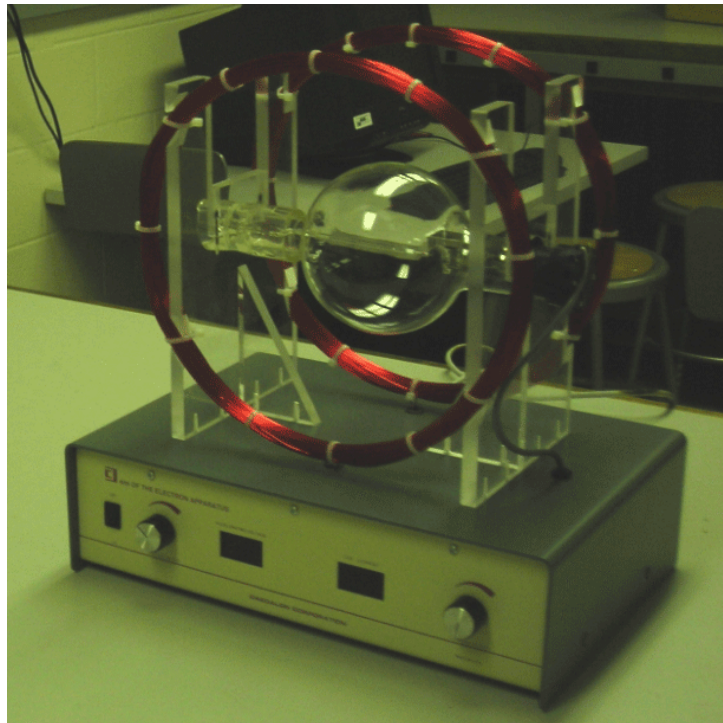

Figure 0.

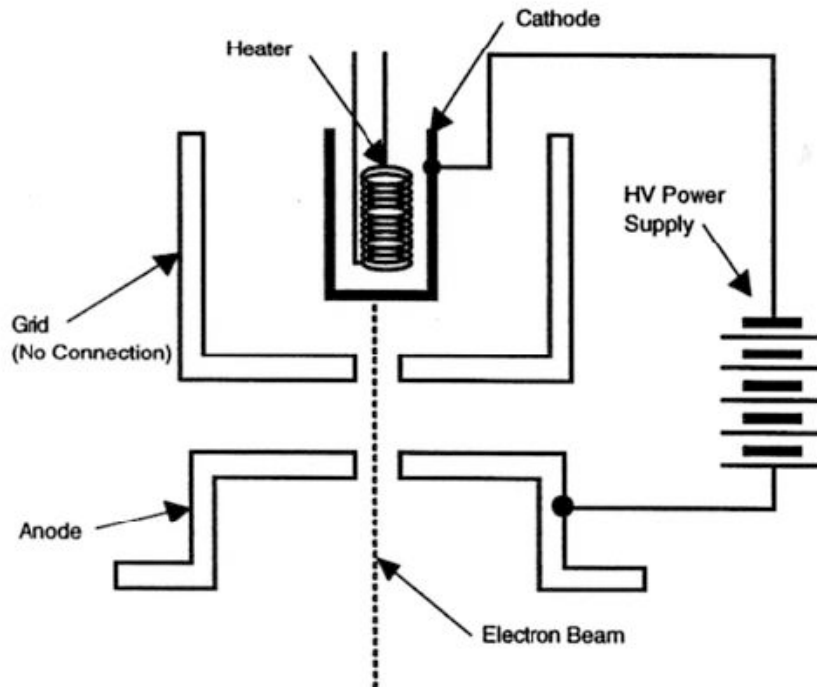

Figure 1

The filament is heated white hot (~ 2000 Kelvin, giving $k_B T \sim 0.2$ eV) by the current flowing through it from the filament supply. The filament is a tungsten wire with a low “work function” energy: $W \sim 2.6$ eV. A small fraction $f \sim \exp(-W/k_B T) \sim 2 \times 10^{-6}$ of the “surface” electrons escape the metal; this is called “thermionic emission.” These electrons are accelerated toward the cylindrical anode can by the voltage V_a applied between the filament and the anode. Most of these electrons strike the inner surface of the anode with a kinetic energy eV_a , and are absorbed. Some electrons, however, pass out through a narrow slot in the anode (also with kinetic energy eV_a), forming a flat ribbon beam of electrons which we use for the experiment.

The tube itself has a small amount of helium vapor added to its otherwise good vacuum. A few of the beam electrons strike helium atoms and excite them (Expt. 5); then the excited helium atoms emit visible radiation and we can thus, “see” where the electron beam is.

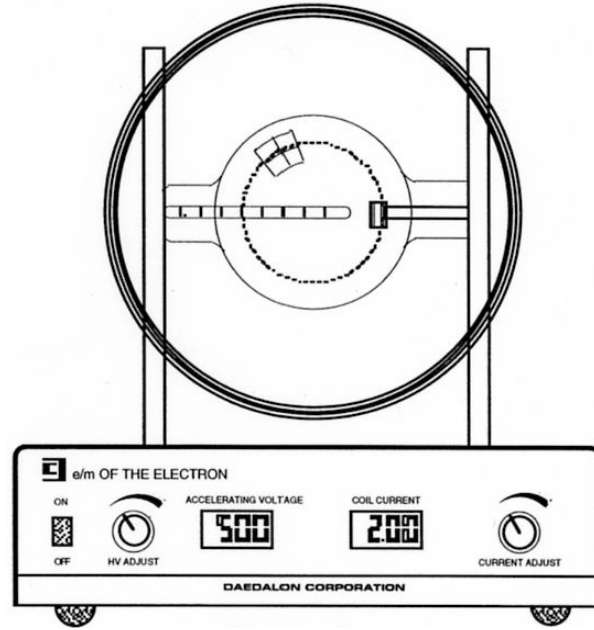

Figure 2

Another feature of this special e/m tube is that it contains a glass scale to permit measurements of the trajectory of the electrons.

When a uniform magnetic field is established throughout the tube, the electron beam will be bent into a circle, as shown by the dotted line in Fig. 2. The radius of the circular electron path is related to the magnetic field and the electron energy in the following simple way. An electron moving in magnetic field experiences a force perpendicular to its velocity – the Lorentz force. It results to centripetal acceleration and curved motion,

$$evB = \frac{mv^2}{r} ,$$

$$\text{or } \frac{e}{m} Br = v$$

(1)

The electron velocity is determined by the cathode-anode voltage V_a applied to the gun, as

$$\frac{m}{2} v^2 = eV_a \quad . \quad (2)$$

Thus we obtain

$$\frac{m}{2} \left(\frac{e}{m} Br \right)^2 = eV_a ,$$

and finally,

$$\frac{e}{m} = \frac{2V_a}{B^2 r^2} \quad (3)$$

In order to perform this experiment we must know r , V_a , and B . r is measured using a glass scale and V_a is simply an applied and measured potential from a variable power supply. How do we obtain and measure B ?

We employ a uniquely useful arrangement of conductors called Helmholtz coils. They are simple, hoop-like coils which are positioned on a common axis and separated by a distance z_0 equal to their radius a . Connected in series with the same polarity, they each have the same current I . In this arrangement, they give a magnetic field which is homogeneous over a fairly large volume near the center. The field is

$$B = \frac{\mu_0 N I a^2}{(a^2 + (z_0/2)^2)^{3/2}} = \frac{8\mu_0 N I}{\sqrt{125}a}, \quad (4)$$

where the second form presumes $z_0 = a$.

Here, $N=130$ is the number of turns per coil, I is the current, $a=0.15$ m is the coil radius, and $\mu_0 = 4\pi \times 10^{-7}$ Weber/Ampere-meter. B is in Webers/m², called Tesla; 1 Tesla = 10^4 Gauss.

The complete apparatus for this experiment, in addition to the vacuum tube and Helmholtz coils, consists of a power supply which controls accelerating potential and the coil current.

Basic lab measurements

Set the gun anode power supply to $V_a = 200$ Volts and measure the beam diameter for 8 coil current settings (a 5-10 minutes warm-up time is recommended before taking careful measurements). The electron beam has a finite width. There are various energy losses from the beam electrons, including scattering from helium atoms, and those electrons which have suffered least loss or no loss have the largest radii of curvature. Therefore, you should measure the outside radius of the electron beam.

Repeat the measurements at $V_a = 300$ Volts and $V_a = 400$ Volts.

Make a separate computation of e/m for each combination of V_a and B . Compute the average, and estimate the statistical error. Estimate your systematic errors from a , V_a and any other effects you can think of.

The accepted value of e/m is 1.76×10^{11} Coulomb/kg.

Optional: Verify if the Earth's magnetic field of 6×10^{-5} T (0.6 Gauss) is negligible in this experiment by rotating the apparatus.

EXPERIMENT #5

The Franck-Hertz Experiment: Electron Collisions with Mercury

GOALS

Physics

- Measure the energy difference between the ground state and the first excited state in mercury atoms, and conclude that there are discrete energy levels in atoms.

Techniques

- Learn how to use Oscilloscope (read manual on 2DL WebCT site before lab).
- Compare the oscilloscope and the x-y recorder as instruments for measuring the collector current as a function of electron accelerating voltage.
- Learn how to optimize experimental conditions for obtaining useful data.

Error Analysis

- Determine whether your mean value for the energy difference is in reasonable agreement with one of the principal lines in the mercury spectrum.

Question (work out the following before coming to 2D lab)

- What are the wavelengths of the three longest wavelength lines in the Balmer series of spectral lines for hydrogen (Fig. 1)?

Important Constants

$$c = 3 \times 10^8 \text{ m/s}$$

$$e = 1.6 \times 10^{-19} \text{ coul}$$

$$h = 6.64 \times 10^{-34} \text{ J} \cdot \text{s} = 4.15 \times 10^{-15} \text{ eV} \cdot \text{s}$$

References

- Serway, Moses, Moyer §3.5
- Tipler & Llewellyn §4-5

BACKGROUND and THEORY

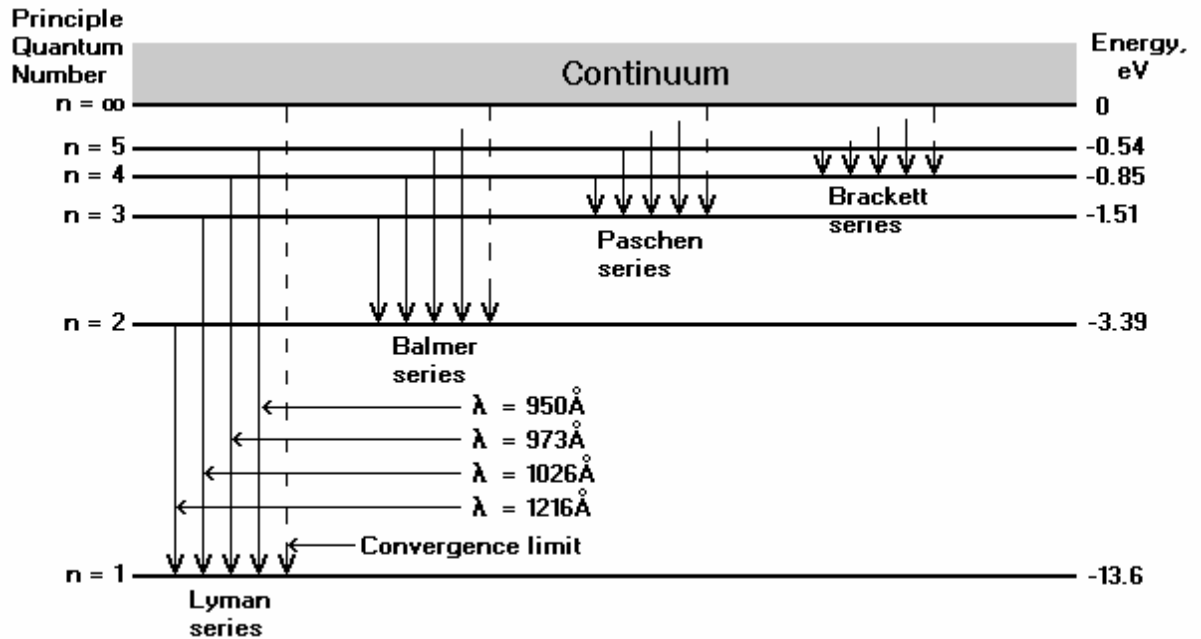

Figure 1: Energy level diagram of the hydrogen atom.

The simplest modern model of an isolated atom consists of a positively charged nucleus about which electrons are distributed in successive orbits. Niels Bohr introduced this “planetary model” of the atom in 1913 to account for the wavelengths present in the atomic spectrum from hydrogen gas. He also postulated that only those orbits occur for which the angular momentum of the electron is an integral multiple of $h/2\pi$, i.e. $n h/2\pi$, where n is an integer and h is Planck’s constant. Using this non-classical postulate together with some relations from classical physics, Bohr showed that the energies of the electrons occupying these allowed orbital states had a simple dependence on the integer n , namely:

$$E_n = \frac{-m_e e^4}{8\epsilon_0^2 h^2 n^2}, \quad n=1,2,3,\dots \quad (1)$$

where m_e is the mass of the electron and ϵ_0 is the permittivity of free space. Note that these energies are negative, so that the lowest energy occurs when $n=1$.

Instead of expressing the energy in joules, it is sometimes convenient to use the energy unit of electron volts (eV), where 1 eV is the energy gained by an electron in passing through a potential difference of 1 volt. Since $e = 1.6 \times 10^{-19}$ Coulomb, we obtain $1 \text{ eV} = 1.6 \times 10^{-19}$ Joule. Equation (1) can then be written as

$$E_n = \frac{-13.6}{n^2} \text{ eV} . \quad (2)$$

Note that the inverse square dependence of the energy levels produces a relatively large energy difference between the levels associated with small n , whereas the higher levels are very close to each other.

In classical physics, a charged particle in an orbit will radiate energy, because it is accelerating. Thus a classical planetary electron would soon radiate away its energy and no longer remain in orbit. This led Bohr to his second non-classical postulate: an electron remaining in one of the allowed orbital states does not radiate energy; radiation is emitted only when an electron goes from a state of higher energy (n_2) to a state of lower energy (n_1), where $n_2 > n_1$. The energy of the quantum of radiation emitted, $h\nu$, is equal to the difference in energy of the two states.

This second Bohr postulate thus implies that

$$h\nu = E_{n_2} - E_{n_1}$$

where ν is the frequency of the emitted radiation and E_n is in Joules. If we substitute the expression of E_n from Eqn. (1),

$$\nu = \frac{m_e e^4}{8\epsilon_0^2 h^3} \left(\frac{1}{n_2^2} - \frac{1}{n_1^2} \right) .$$

It is conventional to write this expression in terms of the “wave number,” or inverse wavelength, as

$$\frac{1}{\lambda} = \frac{\nu}{c} = R \left(\frac{1}{n_1^2} - \frac{1}{n_2^2} \right) \quad ; \quad (3)$$

here $R = \text{Rydberg}$ which is a constant with units of inverse length $= \frac{m_e e^4}{8\epsilon_0^2 h^3 c} = 1.097 \times 10^7 \text{ m}^{-1}$

The wavelengths of some of the hydrogen spectral lines as calculated from Eqn. (3) are shown in Fig. 1, and they agree with experimental observations, confirming the predictions of the Bohr model with its non-classical postulates. Bohr pictured electrons in discrete states with transitions among those states producing radiation whose frequency is determined by the energy differences between states. This can now be derived from quantum mechanics.

It seems reasonable from the Bohr model that just as electrons may make transitions down from allowed higher energy states to lower ones, they may also be excited up into higher energy states by absorbing precisely the amount of energy representing difference between the lower and higher states. James Franck and Gustav Hertz showed that this was the case in a series of experiments reported in 1913, the same year that Bohr presented his model.

In its lowest energy, with $n = 1$, the atom is said to be in its ground state. From Fig. 1, we see that raising the electron in a hydrogen atom from the ground state ($n=1$) to its next highest state ($n=2$) requires an energy absorption of $(13.6 - 3.39) = 10.21$ eV. This energy may be provided in several ways. The atom may absorb a photon, as in the photoelectric effect experiment. Alternatively, if we heat the gas, the excitation may come from the mean kinetic energy of an atom $E = 3/2 kT$, where **Boltzmann's constant**

$$k = 1.38 \times 10^{-23} \text{ J} \cdot \text{K}^{-1} = 8.6 \times 10^{-5} \text{ eV} \cdot \text{K}^{-1}$$

This thermal kinetic energy would be converted in a collision, into excitation energy. We may calculate the gas temperature required to provide 10.21 eV of thermal excitation energy:

$$10.21 = 3/2 kT, \text{ giving } T = 8 \times 10^4 \text{ K} .$$

Obviously, such a high temperature isn't practical for laboratory experiments.

THE FRANK-HERTZ EXPERIMENT

A more convenient way is to accelerate a beam of electrons in an electric field and permit these electrons to collide with the electrons in the gas atoms. In this way, energy may be transferred from the electron beam to the gas atoms. If the energy of the electrons in the beam is less than the energy separation of the ground state from the first excited state, then no energy is transferred and the collisions are elastic. If the beam energy is equal to or greater than the separation of the lowest states, then energy is absorbed equal to the energy separation of the states and the collision is called inelastic. The beam electrons may be left with some of their initial energy if that energy is greater than the energy separation of the two levels.

Franck and Hertz used a beam of accelerated electrons to measure the energy required to transfer electrons in the ground state of a gas of mercury atoms to the first excited state. A schematic diagram of their apparatus is shown in Fig. (2).

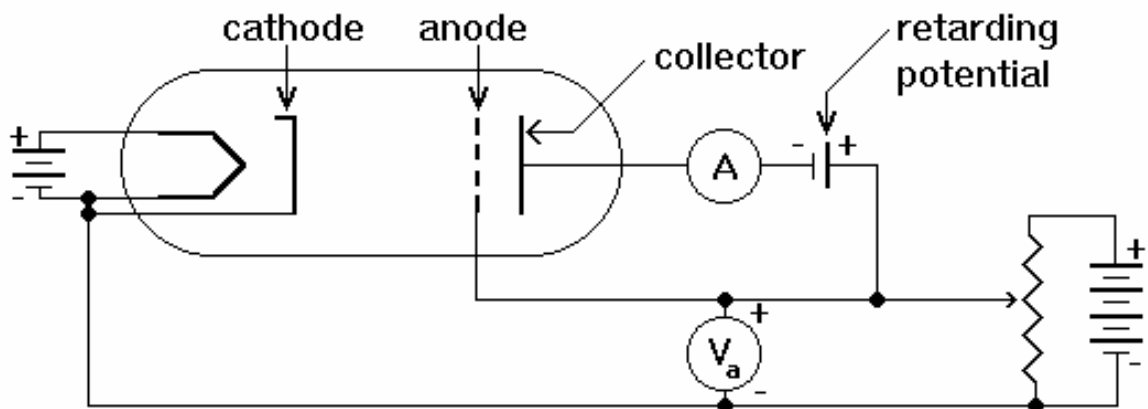

Figure 2a: Franck-Hertz Tube

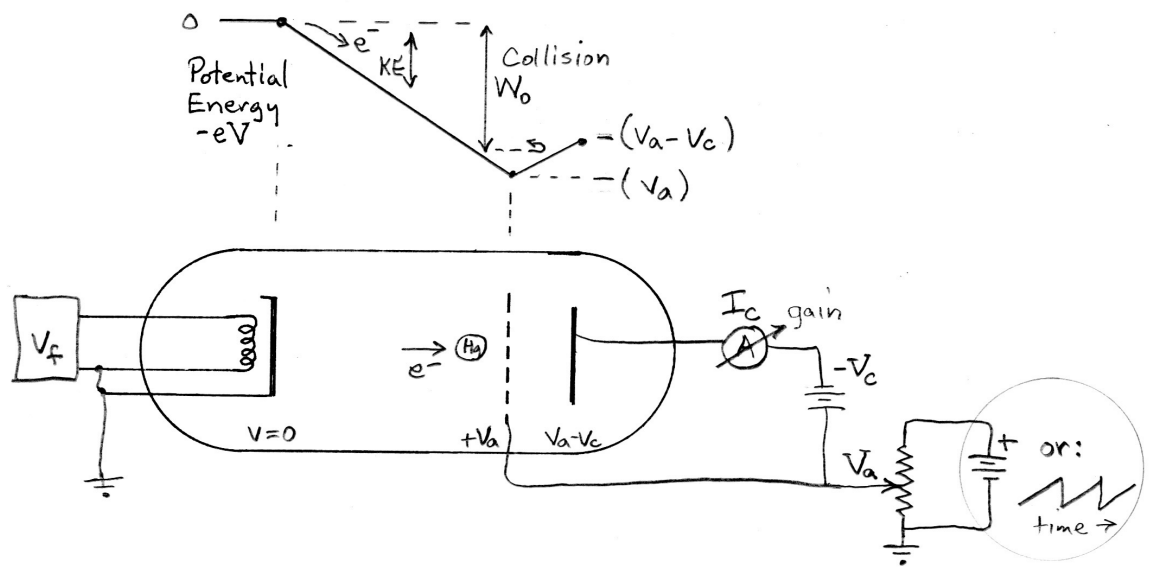

Figure 2b Franck-Hertz Tube and energy diagram.

The sealed tube contains a small amount of mercury which is vaporized by heating the tube with a surrounding furnace. The tube contains a cathode which is heated to produce electrons, a perforated anode maintained at a positive accelerating voltage V_a with respect to the cathode, and a collector electrode held at a small retarding voltage V_c that is negative with respect to the anode. An ammeter, A , measures the collector current. Fig. 3 shows the collector current as a function of anode voltage.

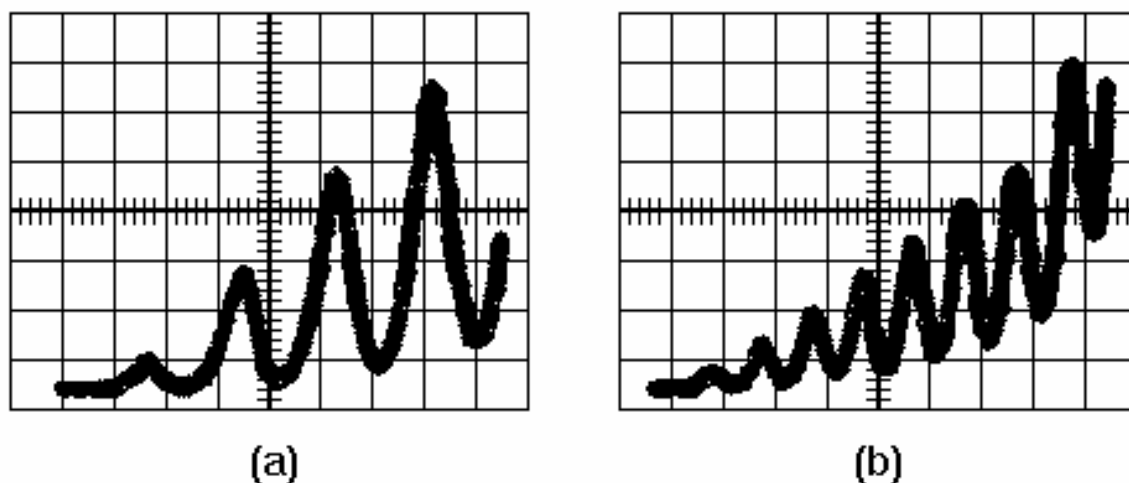

Figure 3: Oscilloscope traces of Franck-Hertz collector current vs. anode voltage. (a) Trace for lower temperatures; (b) Trace for higher temperatures, with different x and y scales.

Electrons emitted by the cathode are accelerated by voltage V_a as they move toward the anode. When eV_a is less than the energy $E(2,1) = E(n=2) - E(n=1)$, only elastic collisions will occur between the electrons and the mercury atoms. The accelerated electrons will pass through the perforated anode and will be measured at the collector. When the eV_a is equal to $E(2,1)$ the collector current begins the drop because some electrons make inelastic collisions with mercury atoms and cannot overcome the potential barrier V_c . The current rises as V_a is increased further, since electrons can now make inelastic collisions before reaching the anode and still gain enough energy to reach the collector.

As V_a is increased still further, successive minima in collector current occur with a spacing of
$$V = \frac{E(2,1)}{e}$$
. They occur because an electron can now gain enough energy to make an inelastic collision well before reaching the anode. This electron can gain additional energy to make a second inelastic collision with a second minimum in the collector current.

This process will repeat as V_a is increased, producing a series of equally spaced minima in the measured collector current as shown in Fig. 3. From the spacing of the minima we can calculate the energy difference between the ground state and first excited state. You will note that the first minimum appears at a voltage larger than the voltage between the succeeding equally spaced minima. This results from the fact that the electrons must surmount the reverse bias voltage as well as a "contact potential" that exists between the cathode and anode. The number of minima you observe is dependent on the furnace temperature. At low temperatures (around 150° C) the voltage difference between maxima and minima are large and the first few minima are clearly distinguished but the current saturates at a relatively low accelerating voltage (Fig. 3a). At higher temperatures, more minima appear, but the initial ones

may be difficult to measure accurately (Fig. 3b). This measured difference between successive minima permits us to predict the frequency or wavelength of the radiation emitted by a mercury atom when it drops from the excited to the ground state.

Why did Franck and Hertz (and now you) use mercury vapor instead of hydrogen gas? The reason is that hydrogen atoms combine in pairs to form hydrogen molecules. Therefore, some of the energy lost in inelastic collisions of the electrons with a hydrogen gas would result from separating the hydrogen molecules into atoms and this would complicate the analysis of the measured collector current. A mercury gas consists of single atoms.

However, mercury atoms have 80 electrons (and protons) instead of the one for hydrogen. A more detailed quantum mechanical analysis is thus required to account for the energies of all these electrons. However, for the purposes of the Franck-Hertz experiment, it is sufficient to note that 78 of these electrons are bound much more strongly to the nucleus than the remaining two. Therefore inelastic collisions of the mercury atoms with the accelerated electrons only excite these more weakly bound "outer" electrons. The collector current will measure the difference between the ground and first excited state of these "outer" electrons.

THIS EXPERIMENT

PURPOSE

The purpose of this experiment is to produce a Frank-Hertz signal on the oscilloscope screen, and from that measure the difference between the ground state and first excited state of mercury atom electrons.

EQUIPMENT

1. A control unit for the Franck-Hertz tube,
2. A thermometer
3. The Franck-Hertz tube mounted in a cabinet containing a heater.
4. An oscilloscope and X-Y recorder.
5. Connecting leads and cables.

EXPERIMENTAL SETUP

The tube-heater unit has a diagram of the tube on the front showing the connector locations for the cathode heater, cathode, anode, and collector. The control unit has several channels:

Signal channel

The top knob controls the gain (amplification) of the collector current circuit. The output display voltage is proportional to the measured current. 1 V output voltage corresponds to an input current of $0.7 \mu\text{A}$ in the minimum sensitivity setting (control knob counter-clockwise), and to an input of 7nA in the

maximum (clockwise) setting. Output voltages are of order 10 volts. The bottom knob adjusts the reverse bias of the collector with respect to the anode.

Acceleration channel

The acceleration voltage, V_a , is varied from 0 to 70 V with the knob. V_a can be a repetitive 60 Hz sawtooth wave for use as the x-deflection on the oscilloscope (switch in ramp position), or it can be adjusted manually for providing the DC x-axis signal on the recorder (switch in manual position).

Heater channel

The heater voltage is adjusted with this knob. Increasing the voltage will increase the total kinetic energy of the electrons, which allows more electrons to reach the collector.

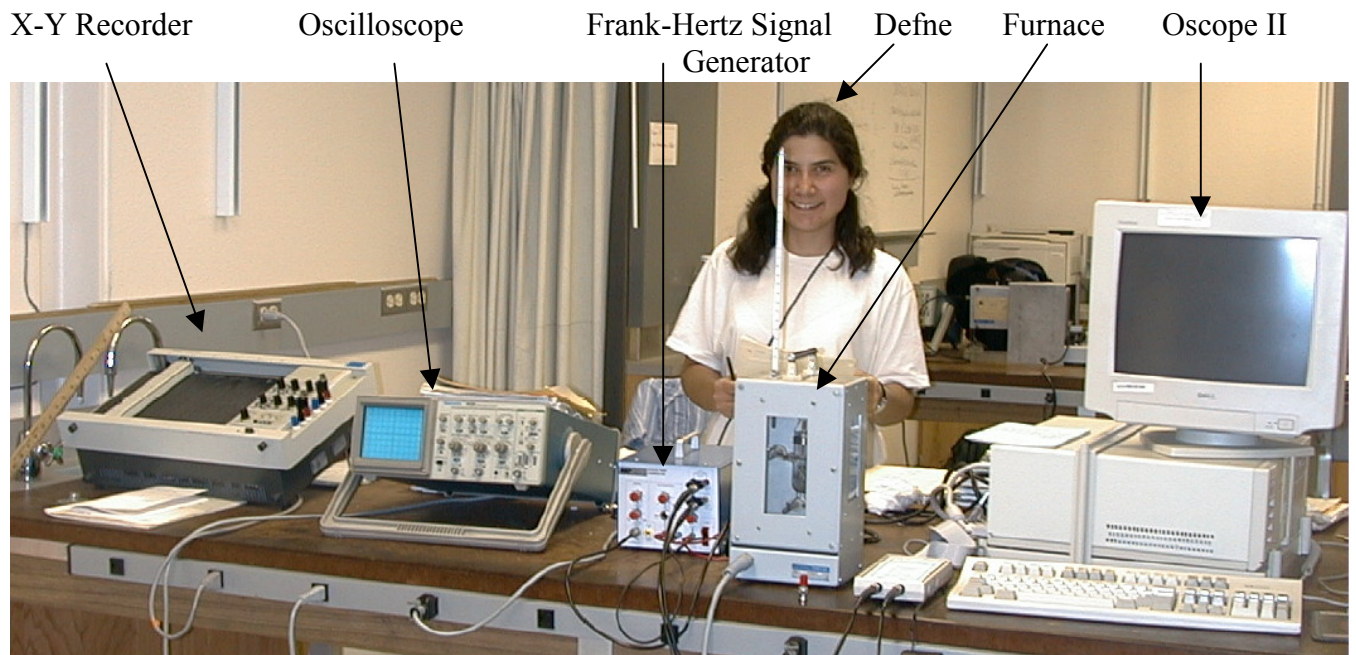

Figure 4

CAUTION

The outside of the cabinet containing the Franck-Hertz tube gets extremely hot when the furnace power is ON. Make all your connections while the furnace power is OFF. You will be severely burned if you touch any part of the cabinet or connector plugs while the power is ON. Remember to turn OFF the furnace power when you complete your experiment. The temperature is controlled by a knob on the side of the cabinet.

PROCEDURE

PART A: Oscilloscope in X-Y mode

1. Familiarize yourself with the oscilloscope.
2. Make sure all power is switched off and the furnace temperature control knob is at the white line before connecting the tube and furnace module, control unit and oscilloscope. $V_a/10$ is the x-axis voltage and the collector current output is on the y-axis. Insert the thermometer to the center of the furnace from the top of the tube/furnace module.
3. Set the temperature control on the side of the furnace to give about 170° C. This control is a bimetal contact switch that will maintain the furnace temperature with about $\pm 6^{\circ}$ C of a mean temperature. It takes 10-15 minutes for the furnace to reach this "equilibrium" from a cold start.
4. Switch on the control unit. Set the V_a switch to "ramp". Set the filament heater and retarding potential at about mid-position.
5. Slowly increase V_a from a zero position until you see a Frank Hertz signal similar to Fig. 3. This will require adjusting the gain control and the cathode heater control.
6. You will be able to measure the minima spacings under a variety of conditions; however, no quantitative measurements should be made at this point. Which are the best conditions for obtaining the most reliable results?(Hint: refer to the Frank-Hertz Experiment Section.) What are some important sources of uncertainty in these results?

PART B: X-Y recorder or O-scope Software

The X-Y Recorder or O-scope Software (which uses LabView data acquisition (DAQ) program and National Instruments analog-to-digital data acquisition hardware) will be used to make quantitative measurements of the Frank-Hertz signal achieved in Part A. The TAs will discuss operation of the X-Y recorder and/or DAQ hardware/software. If you use it, be careful not to damage the sweep arm mechanism of the Yokogawa X-Y recorder by leaning on it or otherwise mechanically loading it.

1. Set the furnace temperature to a convenient value.
2. Connect the signal output to the y-axis and $V_a/10$ to the x-axis. Set V_a to zero (full counterclockwise) and the V_a switch to manual.
3. Set the cathode heater midway.
4. Switch on the power.

5. Set the signal gain to maximum (fully clockwise).
6. Adjust the reverse bias so that the signal output is zero.
7. Slowly increase V_a and adjust the gain to keep the signal on the chart.
8. Compute corresponding average minima spacings and their uncertainties.
9. You should try to find the best conditions for producing useful data. Discuss these conditions and the resulting data as for the oscilloscope measurement. Include several (4-5) sample x-y readouts in your notebook. Do you feel one measurement method (Part A and Part B) is more reliable than the other?
10. Use error analysis to determine the best value for the energy and wavelength corresponding to the difference between the ground state and first excited state for mercury. Some of the principal lines in the mercury spectrum are **185.0, 253.7, 435.8, 546.1 and 579.1 nm**. Does your best value agree with any of them?

TROUBLE-SHOOTING

- Make sure the BNC cables are not reversed and that the oscilloscope is in XY mode on the time control knob.
- Use the **Heater Channel** to adjust low and high temperature readings, **not the furnace temperature control**.

You will be able to measure the minima spacings under a variety of conditions. Compute the corresponding average spacings and their uncertainties for these different conditions. Which are the best conditions for obtaining the most reliable results? What are some important sources of uncertainty in these results?

You should produce paper versions of I vs. V_a , using either the X-Y Recorder or the PC LabView data acquisition program. Set the V_a switch to “manual” and vary V_a by hand. Ask the TA for technical help with the recorders. Include a sample x-y graph in your notebook. Which measurement method do you feel is more reliable? Why?

Use error analysis to determine the best value for the energy and wavelength corresponding to the difference between the ground state and first excited state for mercury. Does your best value agree with any of them?

EXPERIMENT #6

Electron Diffraction

GOALS

Physics

- Demonstrate that accelerated electrons have an effective wavelength, λ , by diffracting them from parallel planes of atoms in a carbon film.
- Measure the spacings between two sets of parallel planes of atoms in carbon.

Techniques

- Control the wavelength of the electron beam by varying the accelerating voltage.
- Use the De Broglie expression for the wavelength of the electrons and the Bragg condition for analyzing the diffraction pattern.

Error Analysis

- Calculating the uncertainties in the data points on your graph gives you a good opportunity to use the principles of error propagation.

Question (work out in lab book before class)

1. Derive an expression for the extrapolated value of the diffraction ring of diameter D' shown in Fig. 11. HINT: start with the fact that D is the chord of a circle with a 66 mm radius.

References

- Serway, Moses, Moyer §4.2
- Tipler & Llewellyn §5-1, 5-2

BACKGROUND AND THEORY

Several of your laboratory experiments show that light can exhibit the properties of either waves or particles. The wave nature is evident in the diffraction of light by a ruled grating and in the interferometer experiments. In these experiments, wavelength, phase angle, and coherence length of wave trains were investigated--all features of wave phenomena. However, the photoelectric effect requires a model in which light consists of discrete bundles or quanta of energy called photons. These photons behave like particles. There are other examples illustrating this dual nature of light. Generally, those experiments involving propagation of radiation, e.g. interference or diffraction, are best described by waves. Those phenomena concerned with the interaction of radiation with matter, such as absorption or scattering, are more readily explained by a particle model.

Some connection between the wave and particle models can be derived by using the principle of the equivalence of mass and energy introduced by Einstein in 1905 in his special theory of relativity, namely,

$$E = mc^2 .$$

In this equation E is the total energy of a body, m is its mass, and c is the velocity of light. From the photoelectric experiment we learned that light may be considered to consist of particles called photons whose energy is

$$E = hf$$

where f is the frequency of light and h is Planck's constant. We may equate these two energies and obtain:

$$\begin{aligned} mc^2 &= hf, \text{ or} \\ mc &= hf/c = h/\lambda \end{aligned}$$

where λ is the wavelength of the light. Now mc is the momentum of a photon with equivalent mass m traveling with velocity c. Thus the momentum of radiation may be expressed either in terms of the wave characteristic λ or by the mass and velocity of the equivalent particle.

This dual situation with respect to radiation led de Broglie in 1925 to suggest that a similar duality should exist for those entities which had previously been regarded as particles. Thus, a particle such as an electron with mass m, traveling with velocity v, has a momentum mv. De Broglie stated that this particle could also behave as a wave and its momentum should equal the wave momentum, i.e.

$$\begin{aligned} mv &= h/\lambda, \text{ or} \\ \lambda &= h/mv . \end{aligned}$$

It was then a question of verifying this hypothesis experimentally. If an electron is accelerated through a potential difference V, it gains a kinetic energy

$$\frac{1}{2}mv^2 = eV, \text{ or}$$

$$mv = \sqrt{2emV}$$

where e is the electron charge and m is its mass. Substituting this value for v in the de Broglie expression for the wavelength gives

$$\lambda = \frac{h}{mv} = \frac{h}{\sqrt{2meV}} = (1.23 \times 10^{-9} \text{ m}) \left(\frac{V}{1 \text{ volt}} \right)^{-1/2} \quad (1)$$

Thus it should be fairly simple to produce a beam of electrons of a known wavelength by accelerating them in a voltage V . This beam could then be used in experiments designed to demonstrate wave properties, e.g. interference or diffraction.

One might try to diffract the beam of electrons from a grating. However, the spacings between the rulings in man-made gratings are of the order of several hundred nm. From Equ. (1), we find that even with an accelerating voltage as low as 1. V, the electron wavelength is only 1.2 nm. As we will see shortly, such a large difference between the grating spacing and the electron wavelength would result in an immeasurably small diffraction angle.

It was recognized, however, that the spacings between atoms in a crystal were of the order of a few tenths of a nm (1 Angstrom = 0.1 nm). Thus, it might be feasible to use the parallel rows of atoms in a crystal as the "diffraction grating" for an electron beam. This possibility seemed particularly promising since it had been found that x-rays could be diffracted by crystals, and x-ray wavelengths are similar to the wavelengths of 100 eV electrons.

Figure 1 shows some of the possible arrangements of atoms in a cubic pattern. (a) is the simple cubic form. When an atom is placed in the center of the simple cube, we get (b), the body-centered-cubic form.

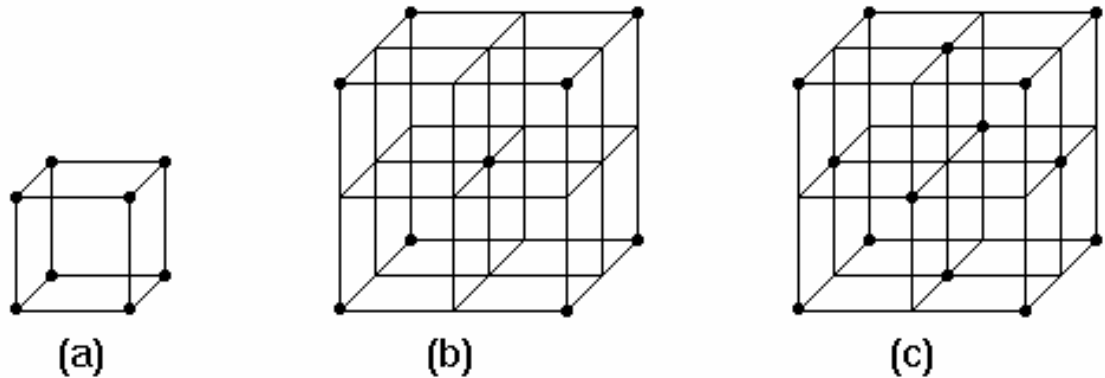

Figure 1: Three cubic arrangements of atoms in a crystal. (a) simple cubic, (b) body centered-cubic, (c) face-centered cubic

When atoms are placed on the faces of the cube, as in (c), the arrangement is called face-centered-cubic. For example, the atoms in nickel and sodium chloride are arranged in the face-centered-cubic pattern. In an iron crystal, the body-centered-cubic arrangement is found.

Figure 2 shows a view of body-centered-cubic atoms looking perpendicular to one of the cubic faces. Three different orientations of parallel rows of atoms are distinguished with different spacings between the parallel rows. These parallel rows

of atoms lie in parallel atomic planes, and it is evident that there are a large number of families of parallel planes of atoms in a crystal.

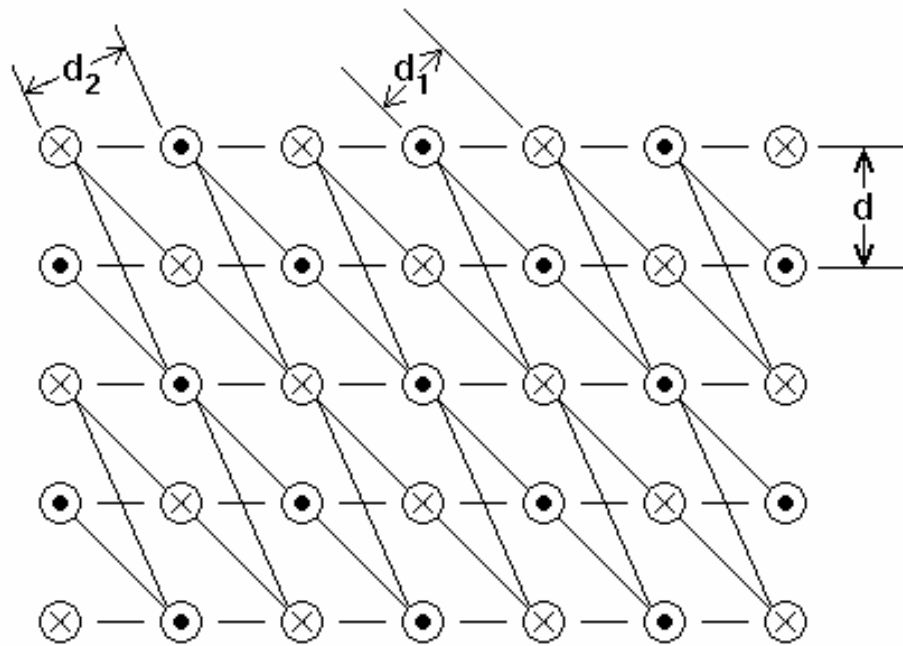

Figure 2: Interplanar spacings, d , of different families of parallel planes in a cubic array of atoms.

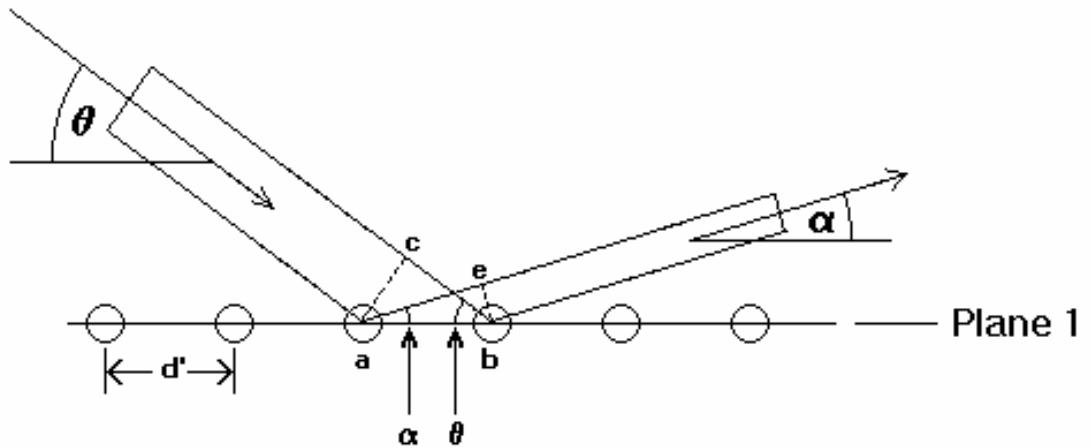

Figure 3: Scattering of waves from a plane of atoms. Path difference for waves from adjacent atoms.

We consider the scattering of waves from a single plane of atoms as shown in Fig. 3. The atoms are spaced a distance d' apart. The incident wave makes an angle θ with a

row of atoms in the surface. \overline{ac} is the wave front. The scattered wave makes an angle α with the surface; its wavefront is \overline{be} . Constructive interference will occur for the rays scattered from neighboring atoms if they are in phase -- if the difference in path length is a whole number of wavelengths. The difference in path length is $\overline{ae} - \overline{cb}$. Therefore

$$\overline{ae} - \overline{cb} = d \cos \alpha - d \cos \theta = m \lambda ,$$

where m is an integer.

Another condition is that rays scattered from successive planes separated by a distance d also meet in phase for constructive interference. Figure 4 shows the construction for determining this condition.

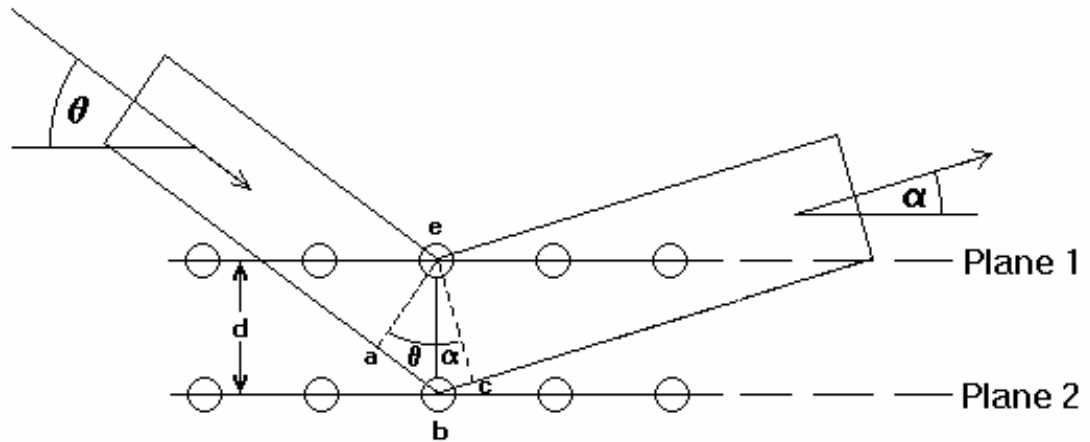

Figure 4: Path difference for waves scattered from successive planes of atoms.

The difference in path length for rays traveling from planes 1 and 2 is seen to be $\overline{ab} + \overline{bc}$, the extra distance traveled by the ray scattered from plane 2. This path difference must again be an integral number of wavelengths. Therefore

$$\overline{ab} + \overline{bc} = d \sin \theta + d \sin \alpha = n \lambda$$

These conditions can be satisfied simultaneously if $\theta = \alpha$. In that case $m = 0$ satisfies the first condition and

$$n \lambda = 2 d \sin \theta$$

satisfies the second condition.

This relation was developed by Bragg in 1912 to explain the diffraction of x-rays from crystals. The parameter n is called the “order” of the diffraction spectrum.

Thus the conditions for constructive interference are that the incident and scattered beams make equal angles θ and that the relation $n\lambda = 2d\sin\theta$ must be obeyed where d is the spacing between parallel adjacent planes of atoms.

In 1927, Davisson and Germer at the Bell Telephone Laboratories investigated the scattering of a beam of electrons from a nickel crystal. Figure 5 shows, schematically, the essentials of their apparatus.

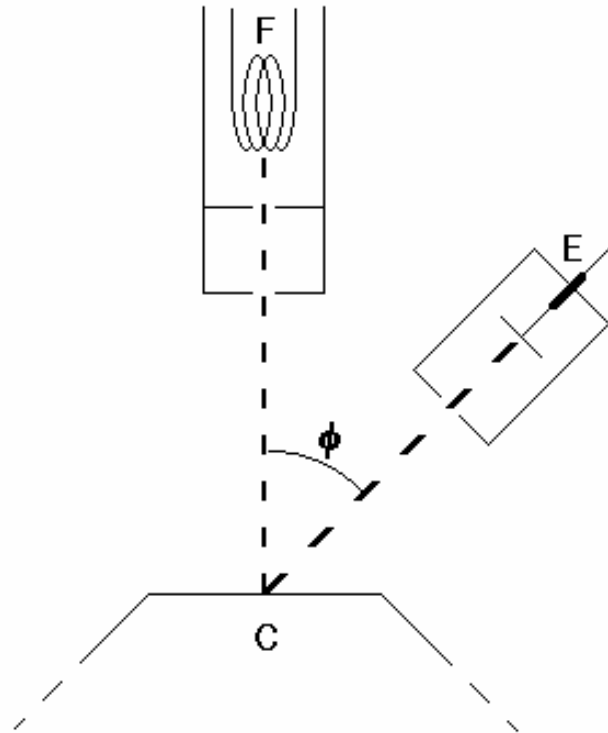

Figure 5: Experimental arrangement for the Davisson-Germer electron diffraction experiment.

Electrons from the heated filament F , were accelerated through a potential difference of order 100V to a plate P with a small diameter hole. A narrow beam of electrons emerged from the opening in P and was incident normally on the face of the nickel crystal C . The electrode E was connected to a sensitive galvanometer and measured the intensity of the electrons scattered by the nickel crystal at various angles ϕ .

Some of the experimental results are shown in Fig. 6. These are “polar plots” of the beam intensity as a function of the angle ϕ for various accelerating voltages which correspond to the wavelengths indicated. In each plot, a line drawn from the origin to any point on the curve makes the angle ϕ ; the length of a line is proportional to the electron beam intensity at that angle ϕ .

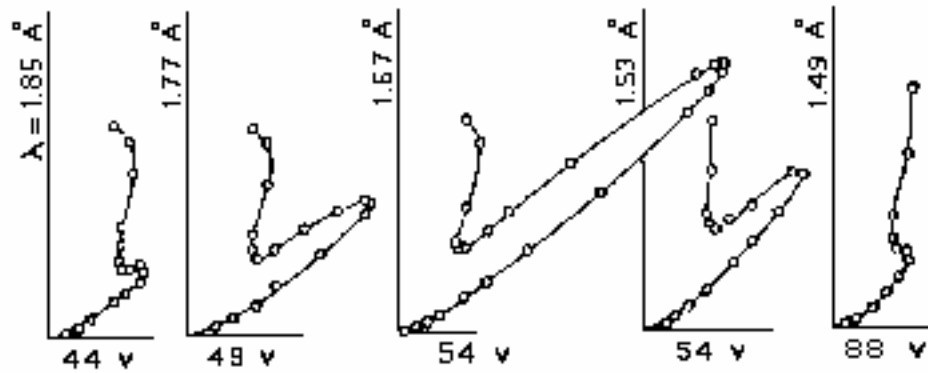

Figure 6: Polar plot of Davisson and Germer's data for the scattered electron beam intensity as a function of scattering angle for different incident electron energies.

As the voltage was increased from 44 to 88 volts, a characteristic peak gradually appears and then disappears. It reaches a maximum for electrons with an energy of 54 eV (.167nm) at an angle of 50°. Davisson and Germer concluded that this peak was due to Bragg reflection from a set of regularly spaced atomic planes within the crystal as shown in Fig. 7.

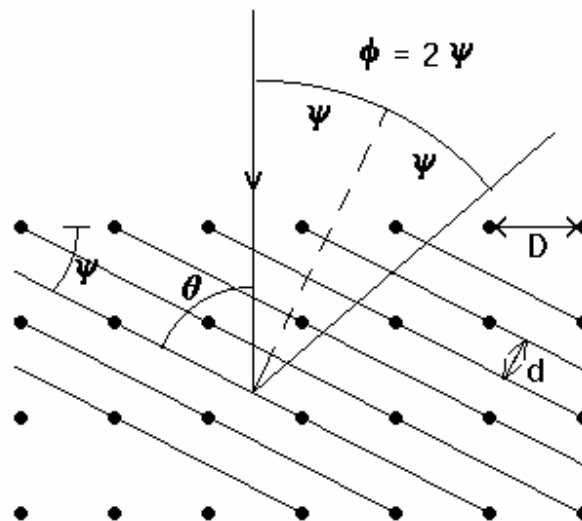

Figure 7: Illustrating the Bragg condition for electron waves scattered from planes of atoms in the nickel crystal used by Davisson and Germer.

The angle $\phi = 2\psi$ is measured in the experiment. The diffracting planes must be normal to the bisector of ϕ , so $\psi = \frac{\phi}{2}$. The angle of incidence θ between the beam and the scattering planes is given by

$$\theta = 90^\circ - \psi = 90^\circ - \frac{\phi}{2}$$

The spacing between the planes involved in the diffraction is d . From x-ray measurements, the spacing D between the surface atoms was known to be 0.215nm. If the diffraction planes make an angle ϕ with the surface, then $d = D \sin \phi$.

Therefore, the measured scattering angle of $\phi = 50^\circ$ determines d as

$$d = D \sin \psi = 0.215 \sin (50^\circ / 2) = 0.215 \sin (25^\circ) .$$

The crystal is apparently oriented such that the angle of incidence is

$$\theta = 90^\circ - 50^\circ/2 = 65^\circ .$$

The Bragg condition for the first order reinforcement then says the electron wavelength is

$$\lambda = 2d \sin \theta = 2[0.215 \sin 25^\circ] \sin 65^\circ = .165nm.$$

The electron wavelength calculated from the de Broglie relation using the known energy of the beam is

$$\lambda = \frac{h}{mv} = 0.167nm .$$

This close agreement convinced Davisson and Germer that they had observed the diffraction of electron waves from the nickel crystal.

In this experiment and in a number of subsequent ones, Davisson and Germer observed that while agreement was close between the observed and calculated diffraction data, there was usually a small discrepancy that was larger for the low energy (longer wavelength) electron beams. They were able to show that this discrepancy was due to the fact that the electrons were refracted as they entered the crystal. The index of refraction, μ , of a crystal was greater than 1, due to the fact that the electrons gained energy on entering the crystal. For those low energy beams where μ (E) differs significantly from 1, the Bragg relation is modified to

$$n\lambda = 2d(\mu^2 - \cos 2\theta)^{\frac{1}{2}}$$

Thus far, only single crystals have been considered. Most materials are polycrystalline. They are composed of a large number of small crystallites (single crystals) that are randomly oriented. An electron diffraction sample may be a polycrystalline thin film, thin enough so that the diffracted electrons can be transmitted through the film.

The experimental arrangement shown in Fig. 8 was used by Thomson in 1927 to study the transmission of electrons through a thin film C. The transmitted electrons struck the photographic plate P as shown. The pattern recorded on the film was a series of concentric rings. This pattern arises from the polycrystalline nature of the film.

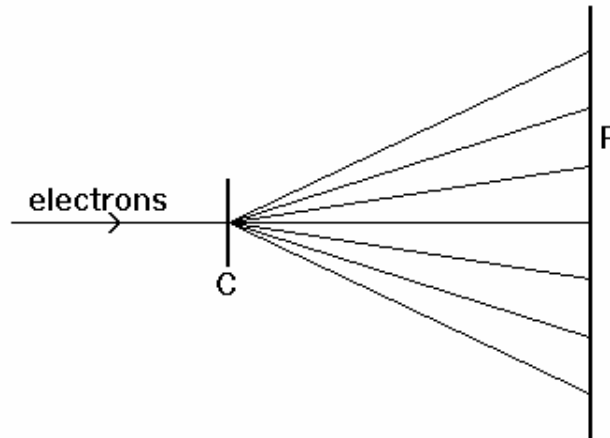

Figure 8: The experimental arrangement used by Thomson for his transmission electron diffraction research.

Figure 9(a) shows a beam of electrons of wavelength λ traveling from the left and striking a plane of atoms in a crystallite. If this plane makes the angle θ with the incident beam such that $\lambda = 2d \sin \theta$, where d is the spacing of successive atomic planes, the beam will be diffracted by the angle $\gamma = 2\theta$.

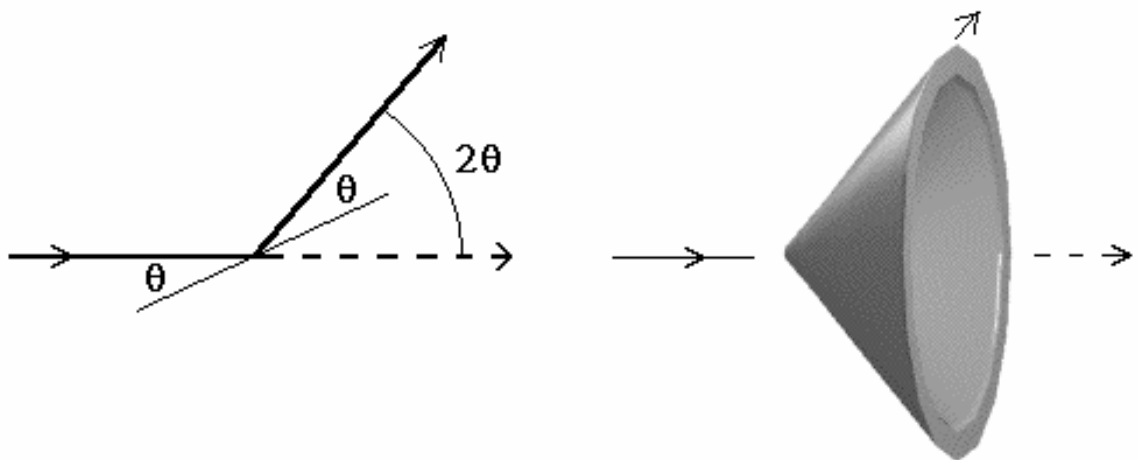

Figure 9: Showing how the randomly oriented crystallites in a polycrystalline film scatter into a cone when the Bragg condition is fulfilled by planes of atoms disposed

symmetrically about the incident beam.

Now there are many randomly oriented crystallites in this film. Thus we may expect that there will be crystallites in which this diffracting plane makes the same angle θ with the beam direction but rotated around the beam in a cone as shown in Fig. 9(b). The diffracted beams from this plane from all the crystallites in the sample will fall on a circle whose diameter may be determined from the cone angle γ and the distance from the sample to the film or other detector. The Bragg condition becomes

$$n\lambda = 2d \sin \theta \approx 2d\theta = d\gamma .$$

In 1927 the wave nature of electrons was verified by reflection and transmission diffraction experiments using these techniques. For this work Davisson and G.P. Thomson were awarded the Nobel prize in 1937. De Broglie received the Nobel prize in 1929 for his basic insight on the wave nature of matter.

DAVISSON-GERMER EXPERIMENT

Fig. 10 shows the arrangement of the atoms in a carbon crystal; the atoms are located on the corners of hexagons. The two principal spacings of the atom planes are indicated; these spacings are

$$d_1 = 0.123 \text{ nm} \quad \text{and} \\ d_2 = 0.213 \text{ nm} .$$

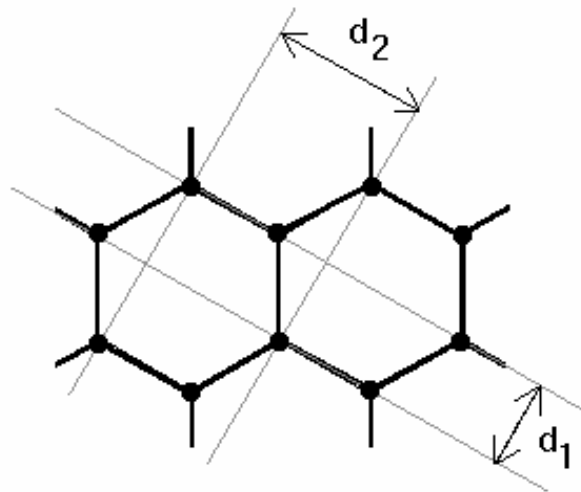

Figure 10: Atom arrangements in carbon showing the two sets of planes that produce the diffraction rings.

As explained above, the diffraction condition for the polycrystalline carbon film is as follows:

$$\lambda = d \gamma .$$

From this equation and from Fig. 9 we can determine the relationship between D' and γ . In Fig. 9, the diffraction cone makes an angle of $\gamma = 2\theta$ from the center line. The value for D' permits you to calculate 2θ from the small angle approximation

$$\gamma = \frac{D'}{2L} .$$

Writing λ in terms of the anode voltage and using $\lambda = d \gamma$ gives

$$\lambda = (1.23 \text{ nm}) V_a^{-1/2} = \frac{D' d}{2L}$$

for the Bragg condition.

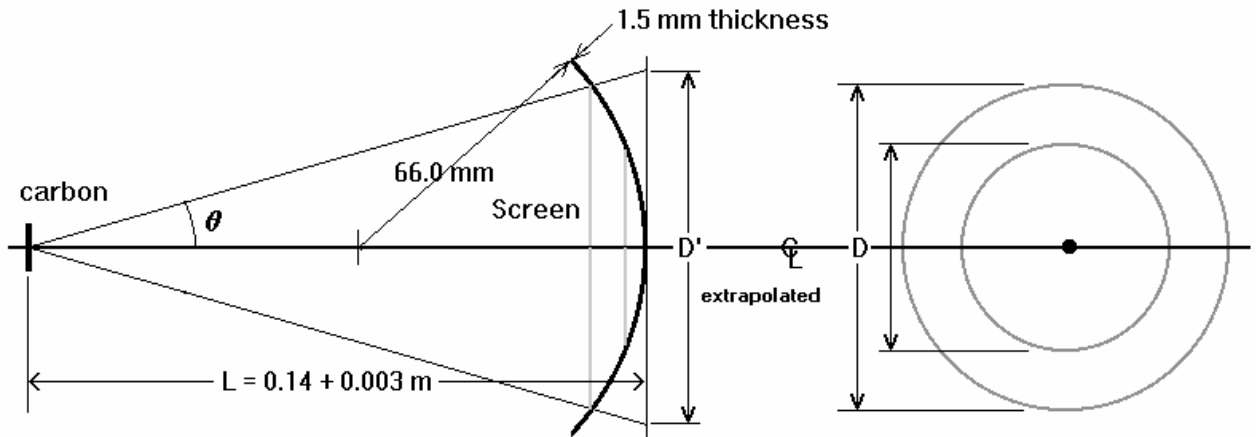

Figure 11: Sketch of the geometry involved in determining the extrapolated ring diameter, D' .

Use this diagram to determine the relationship between D and D' in order to complete all necessary calculations.

THIS EXPERIMENT

PURPOSE

By analyzing the diffraction pattern on the bulb of the Davisson-Germer apparatus, find the spacings between the atoms of polycrystalline carbon film.

EQUIPMENT

1. Electron diffraction tube with carbon thin film target.
2. High and low voltage power supplies.
3. Digital voltmeter for monitoring anode current.
4. Calipers for measuring diffraction ring diameters.

EXPERIMENTAL SETUP

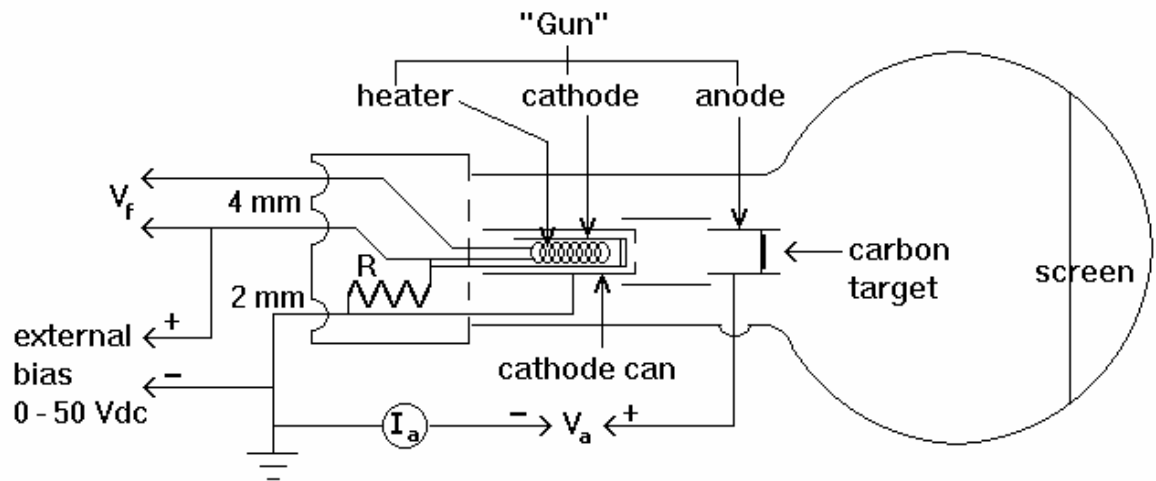

Figure 12: The electron diffraction tube

The electron diffraction tube is sketched in Fig. 12 and Fig. 13 is a picture of this apparatus. The carbon film is mounted in the anode as shown. The variable anode voltage V_a is provided by the 5kV dc supply. Use the outer high voltage terminals.

The electrons are emitted from an indirectly-heated oxide coated cathode. The heater voltage, V_F , is supplied by the 6V output on the 5kV supply. V_F is applied to the 4 mm diameter terminals in the plastic cap at the end of the tube. The external bias V_{bias} for the can surrounding the cathode is provided by the separate power supply. The negative biasing of the can surrounding the cathode serves to focus the electron beam.

The beam current I_a varies with both anode and bias voltages. Be sure to keep the beam current below 0.2 mA as monitored on the DMM in the grounded side of the anode circuit. The 2 mm pin on the back of the tube is the terminal for the negative side of the anode voltage. The positive side of the anode voltage is connected to the 4 mm pin on the side of the tube. The diffraction rings are viewed on the phosphor screen on the glass bulb.

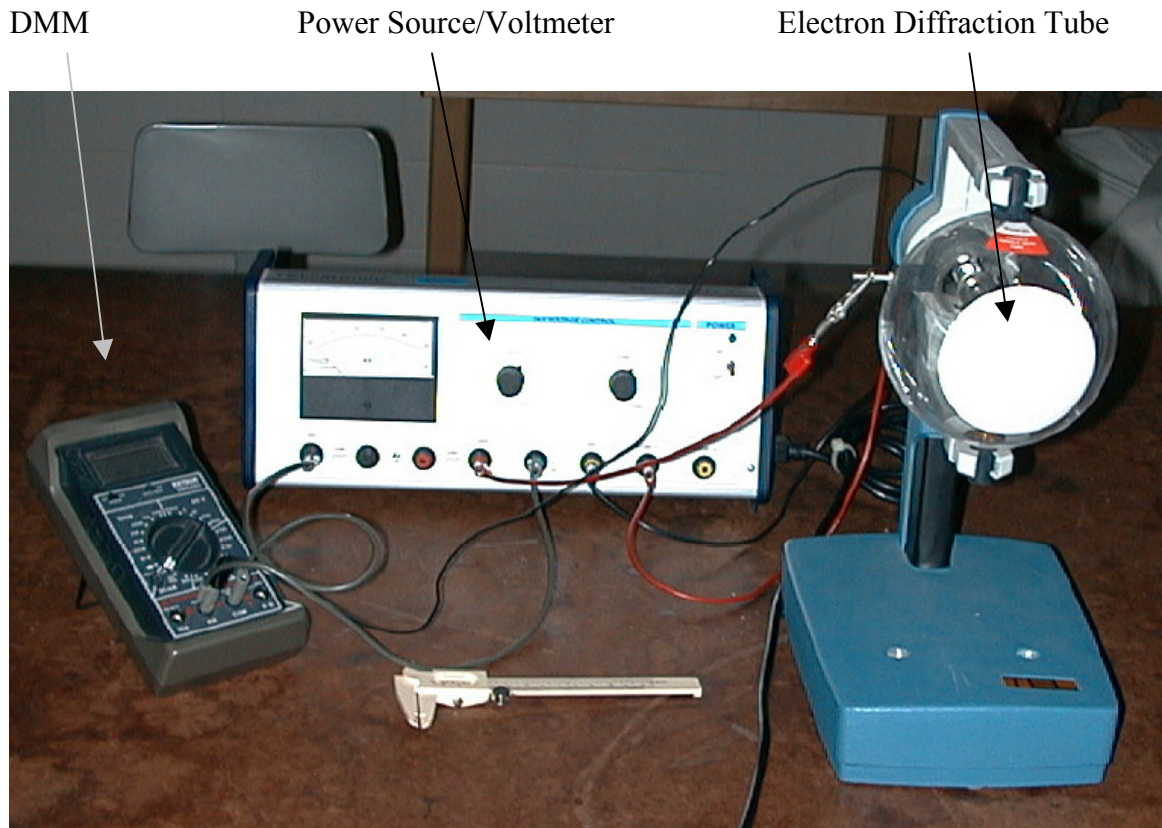

Figure 13

CAUTION

- The 5kV power source can give you a very nasty shock. Verify that your circuit is correctly wired before turning on power. Have your instructor or TA check the circuit.
- Check that the anode current monitoring meter is on the grounded side of the circuit as shown in the diagram below.
- Never permit the anode current to exceed 0.2 mA; otherwise the target may be damaged.

PROCEDURE

1. After having your circuit checked, start the experiment by stabilizing the heater current for about a minute before turning on the anode voltage. The

external bias voltage V_{bias} helps to focus the diffraction rings as well as limiting the anode current to 0.2 mA.

2. As you turn up the anode voltage you will see two rings on the screen, as shown in Fig. 12. Each ring corresponds to one of the carbon d spacings (d_1 or d_2).
3. Measure the ring diameter D on the screen with the calipers.
4. Calculate the extrapolated ring diameter D' , as shown in fig. 12. Take into account both the curvature and thickness of the glass bulb.
5. Calculate γ and λ from D' for each consecutive V_a .
6. Graph Results: For each ring, plot $V_a^{-1/2}$ as a function of D' for a number of values of V .
7. Determine d_1 and d_2 from the slopes of these curves. Using error analysis, compare your values to the d spacings for carbon.
8. What are the most serious systematic errors encountered in this experiment? Could you think of ways to reduce them?

TROUBLESHOOTING

- Darkening your work area will increase your ability to see the rings.
- Measure both horizontal and vertical diameter to ensure accuracy.
- The question at the beginning of this exercise may be solved two ways. Use similar triangles to deduce D' using either the appropriate trigonometric ratios or with the Pythagorean formula.

